





**Drawer cabinets 11**

Drawer cabinets	13
Mobile containers	13
Custom configuration	31



**Drawer partition material 39**

Plastic partition materials	41
Plastic divider sets	43
Metal partition materials, rubber	45
Metal partition material sets	47



**Workbenches 49**

LIGHT workbenches	51
Standard configuration	53
Custom configuration	55



**Workbench extensions 61**

Upright extensions	63
Cabinet extensions	73
Hanging system	81



**Ergonomic workplaces 85**

Ergonomic workplace 240	87
Ergonomic workplace 400	88
ERGO accessories	101



**Electrical accessories 103**

Electric strips	105
Extension cords	107
Lighting	109



**Workshop cabinets 111**

SK cabinets	113
UK cabinets	117

**POLAK CZ – Quality, ecology, reliability**

POLAK CZ is a Czech company that has been supplying top-tier workshop and storage systems to the market since 1994. Our products are a synonym for long service life and reliability.

**Quality guarantee**

We manufacture our products exclusively in our plants in the Czech Republic, which allows us to keep the production process under constant control. The key to this high level of quality is regular investment in the most modern technologies. Automated and robotic production processes increase the precision and efficiency of every production stage, from raw material processing to final assembly.

The foundation of our products, featuring high utility value and modern design, is our own development. This also includes electrical and electronic components.

**Ecology**

Material recycling, energy-efficient technologies, and waste minimization. Recovery of technological waste heat, utilization of heat from a biogas power plant. Rooftop photovoltaic system and complete automatic LED lighting. Own water sources. Minimization of waste and its careful sorting. This is our contribution to sustainability and efficient use of resources.

 **POLAK CZ Company – quality, sustainability, and innovation for the future**



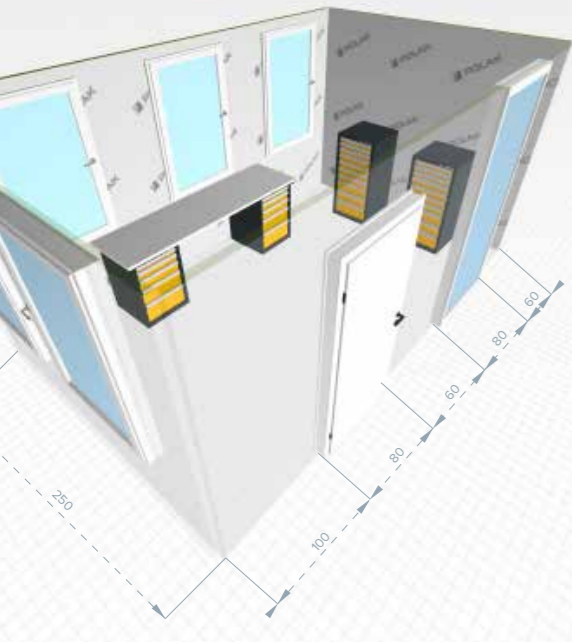

### Workshop furniture configurator

The POLAK CZ range of workshop furniture is extensive, and one of its key strengths lies in the potential for combinations and modularity. With so many ways to combine components, it may be difficult to navigate the product range and achieve the best solutions. That's why we created a tool to guide you through the product configuration – from basic dimensions to detailed accessories. At the same time, you can view your furniture in the 3D planner and adapt it to your own space.

[www.workshop-furniture.com](http://www.workshop-furniture.com)

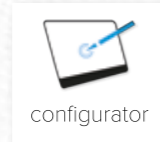

The configurator interface guides you through product assembly from basic dimensions to accessories.

### POLAK smart furniture

Workshop furniture products are equipped with plastic labels featuring NFC and QR technology. These NFC and QR codes instantly connect you to the virtual world of workshop furniture using any compatible reader.

[www.smfu.eu](http://www.smfu.eu)

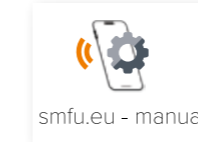

**POLAK SMART FURNITURE**  
Online access to the virtual workshop furniture advisor.



### Furniture tailored to your needs

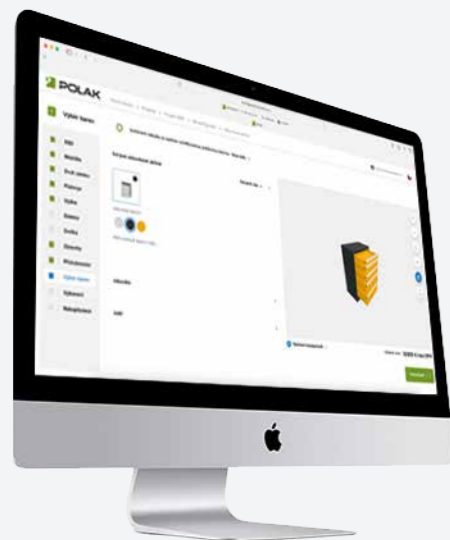

configurator

- Intuitive control
- Custom configuration
- Zero errors in the configuration
- Complete solution including details
- 3D planner with custom room setup
- Up-to-date prices of all products
- User interface
- Instant ordering option
- History of orders and configurations

### Everything you need to know

- Detailed assembly instructions
- Safety instructions
- Product specifications
- Professional tips and advice
- Video tutorials
- Label templates
- Accessories overview
- Electronics wiring guide
- Data sheets and user manuals



smfu.eu - manual



### 3D Planner

To create a complete idea of how your workshop space can be furnished, use our advanced 3D planner. Start by designing your own room with the required dimensions, including windows, doors, and obstacles. You can then easily insert your configured assemblies into the prepared space or use one of our predesigned workshop furniture sets.

produced in Czechia



### NFC / QR scanning

Place, for example, a tablet with a QR code reader near the label to view the assembly manual for your purchased POLAK product, learn about safety guidelines, product care, and how to maximize its features.

The SMFU interface is responsive for all device types.

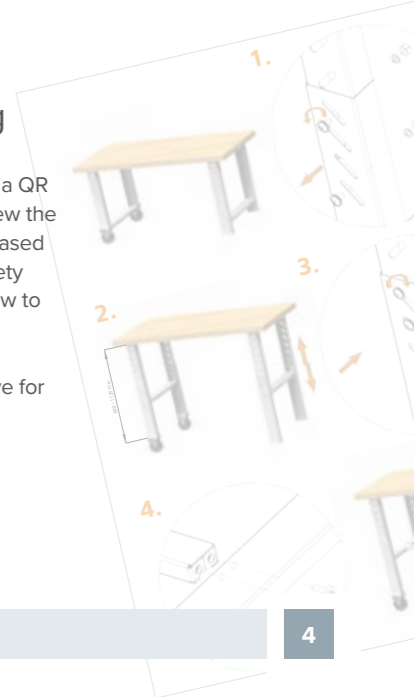



## Electronic locks for drawer cabinets

Electronic locks designed for direct access to drawer cabinets without a key are developed and manufactured by POLAK. **Plastic components of the locks are not ESD conductive.** Power is provided by 4x AA batteries. Battery life is up to 50,000 locking cycles. Optical signaling indicates low battery status. **Detailed manual at [www.smfu.eu](http://www.smfu.eu).**



configurator



3+ RAL colors



smfu.eu - manual



**Code lock**  
Electronic locks for unlocking drawer cabinets using a numerical code feature a full-scale keypad with capacitive control. Unlocking is performed via a custom five-digit code followed by turning the knob. **Locking occurs by returning the knob to its original position.** User comfort is supported by optical and acoustic signaling.

Up to 5 predefined codes can be stored in each lock = up to 5 users of a single lock.

**Manufacturer's master code**  
The user master code is preset by the manufacturer; the user has the option to change the master code.



**Chip lock**  
Electronic locks for unlocking using wireless technology feature an integrated RFID chip, along with optical and acoustic signaling. The lock can be opened by simply presenting the chip followed by turning the knob. Locking occurs by returning the knob to its original position. **The user can set up to 5 chips.** Unlocking by code is not possible. One chip is included in the delivery.

### Spare chip

Ordering number	CHIP



**Micro USB connector**  
Emergency lock opening in case of dead batteries.

**LED diode**  
Green and red flashing signals the correctness of entered values and warns of low battery.

**Numerical coding**  
Capacitive keypad control with numbers, acoustic signaling.

**Card and chip reader**  
Up to 5 chips can be set for unlocking.

## Key locking

Standardly, all workshop furniture and locker products are equipped with cylindrical locks; two keys are supplied with each lock.



### Individual keys

We supply workbenches or drawer cabinets in a "single key" system, where you unlock several locks on one product with one key. However, for each product, you have a unique key.



### Common key

The original lock design allows you, upon request, to open several locks on different workshop furniture products with a single master key. One worker can thus unlock a workshop cabinet, a mobile container, and a drawer cabinet with wwa single key.



General master key



### Two-point locking

All double-wing doors are equipped with the original POLAK two-point locking system. All parts are made of high-strength plastic with glass fiber content, ensuring quiet closing and opening of the doors. **The plastic lock body is not ESD conductive.**



### Single-point locking

The original POLAK plastic handle is a necessity for every lock with a single-point latch. Doors with single-point locking are equipped with a spring-loaded detent mechanism against spontaneous opening of the doors in the unlocked position. **The plastic lock body is not ESD conductive.**



## EPA workplace

The abbreviation **EPA (electrostatic discharge protected area)** refers to workplaces designed for permanent safe handling of components sensitive to static electricity. **They consist of ESD (antistatic) components that maintain electrostatic fields and voltages at negligible levels and eliminate the risk of damage to these components.**

Depending on the nature of the work and the required level of protection, the workplace can be designed based on the variants listed below. It is always true that an EPA area must have clearly defined boundaries so that it is obvious where we enter and where we leave the safe area.

### Variants of EPA workplace



Variant 1

- 1 ESD desk mat  
synthetic rubber, resistant to solder and heat, volume conductive
- 2 ESD wrist strap  
protects the user against electric shock
- 3 Workbench  
without ESD finish
- 4 Work chair  
without ESD finish
- 5 Surrounding area  
without adaptation for ESD

Variant 2

- 1 ESD floor mat  
synthetic rubber, anti-slip, volume conductive
- 2 ESD wrist strap  
protects the user against electric shock
- 3 Workbench  
ESD version, special paint, antistatic worktop, grounding points
- 4 Work chair  
ESD version
- 5 Surrounding area  
without adaptation for ESD



Variant 3

- 1 Workbench  
ESD version, special paint, antistatic worktop, grounding points
- 2 ESD wrist strap  
protects the user against electric shock
- 3 Extension including accessories  
ESD version, special paint, grounding points
- 4 Work chair  
without ESD finish
- 5 Surrounding area  
without adaptation for ESD



Variant 4

- 1 Ergonomic workplace including accessories  
ESD version, special paint, antistatic worktop, grounding points
- 2 ESD wrist strap  
protects the user against electric shock
- 3 Mobile frame  
ESD version, special paint, grounding points, ESD conductive wheels
- 4 Work chair  
ESD version
- 5 Surrounding area  
adapted for ESD
- 6 Workshop furniture  
ESD version, special paint, grounding points, ESD conductive wheels





### Invisible threat to electronics: Everything you need to know about ESD

- ESD is an abbreviation for electrostatic discharge between objects with different electrical potentials
- ESD can cause subtle but serious electronic defects and financial losses
- The greatest risk of ESD is posed to electronic components, especially integrated circuits
- Circuit damage can occur even through ordinary contact with an object or a person with a different potential
- To protect against electrostatic discharge, we offer special variants of workshop furniture in an anti-static version marked with the abbreviation ESD
- We provide certification and precise measurements of EPA workplaces according to standards
- We offer consulting services and design of ESD protected areas
- We provide professional analysis and testing according to ESD standards
- The ESD POLAK program offers comprehensive service, a guarantee of professional services, and a range of top-tier products

- 1** **Drawer cabinets**  
page 13  
**Drawer cabinets** are equipped with antistatic paint, grounding points, and a color finish in **RAL 1028, 7016, and 7035**. Available in several sizes of cabinets and drawers, including accessories.
- 2** **Mobile containers**  
page 13  
**Mobile containers** are equipped with antistatic paint, grounding points, conductive wheels, accessories, and a color finish in **RAL 1028, 7016, and 7035**.
- 3** **Plastic accessories**  
page 41  
**Plastic accessories** made of antistatic plastic (dissipative); various variants of plastic dividers are available.
- 4** **Workbenches**  
page 49  
**Workbenches** in various variants with antistatic paint, grounding points, antistatic ESD laminate worktop, and a color finish in **RAL 1028, 7016, and 7035**.
- 5** **Workbench extensions**  
page 61  
**Workbench extensions**, upright or cabinet-based, equipped with antistatic paint, grounding points, and a color finish in **RAL 1028, 7016, and 7035**.
- 6** **Ergonomic workplaces**  
page 85  
**Ergonomic workplaces** are equipped with antistatic paint, grounding points, and a color finish in **RAL 1028, 7016, and 7035**.
- 7** **Mobile frames**  
page 101  
**Mobile frames** equipped with antistatic paint, grounding points, conductive wheels, accessories, and a color finish in **RAL 1028, 7016, and 7035**.
- 8** **Workshop cabinets SK, UK**  
page 111  
**Workshop cabinets** with grounding points, available in several variants, with full or glass doors, including accessories and a color finish in **RAL 1028, 7016, and 7035**.
- 9** **Work chairs**  
Dissipate static charge from the **seated person if used together with a conductive floor or mat**.

# Drawer cabinets



POLAK drawer cabinets offer wide variability thanks to a large number of models, sizes, and accessories, allowing easy adaptation to the current requirements of the workplace. Housings are welded from high-quality steel sheet; internal perforation at 25 mm intervals facilitates the configuration of storage space and quick rearrangement without tools. The

drawer cabinet is equipped with a central locking mechanism and drawer blocking. ESD variants of the cabinets include metal parts with antistatic powder coating, grounding points, and special conductive plastic accessories, and can be supplemented with antistatic rubber mats. All cabinets meet the requirements of the ČSN EN 61340-5-1 standard.



- 1** Cabinet body  
Available in 10 heights, equipped with a 225-item description label and QR code with a link to SMFU, finished with ESD paint
- 2** Locking  
Standard equipment of the drawer cabinet is a cylindrical lock
- 3** Drawers  
Seven drawer heights available; the drawer is equipped with a description label and smooth full extension, finished with ESD paint
- 4** Doors  
Equipped with their own cylindrical lock; available in full-height door versions or doors with a sill for combination with drawers, finished with ESD paint
- 5** Drawer partition material  
Plastic drawer dividers in variants of boxes or troughs made of antistatic plastic (dissipative) or metal partition material for perfect organization
- 6** Accessories  
Option to equip the drawer cabinet with a suspension bar, internal shelf finished with ESD paint, or a plinth

### Wheels

Choose the appropriate wheel diameter – 100 mm or 125 mm. The set for a mobile container includes a metal reinforcement and always one pair of fixed wheels and one pair of swivel wheels with brakes.



### Drawer cabinet footprints



**Information label and drawer corner protectors**  
Elegant plastic termination of the drawer handle with space for a description label. The label is protected by a transparent cover and plastic plugs on the sides.

**Warning**  
Small plastic parts such as lock bodies, handles, labels, and plugs are not ESD conductive.



**Drawer blocking**  
When one drawer is pulled out, the safety mechanism of the central locking system blocks all other drawers. This prevents the cabinet from tipping forward.



**Full extension**  
The extension design ensures 100% drawer opening, allowing access to its entire area. The guide rails of the extension mechanism are adjustable in the cabinet housing sides by 25 mm. Smooth, quiet operation, maximum load 80 kg.



**Safety catch**  
Drawers are equipped with a catch that prevents spontaneous opening when the mobile container is in motion.

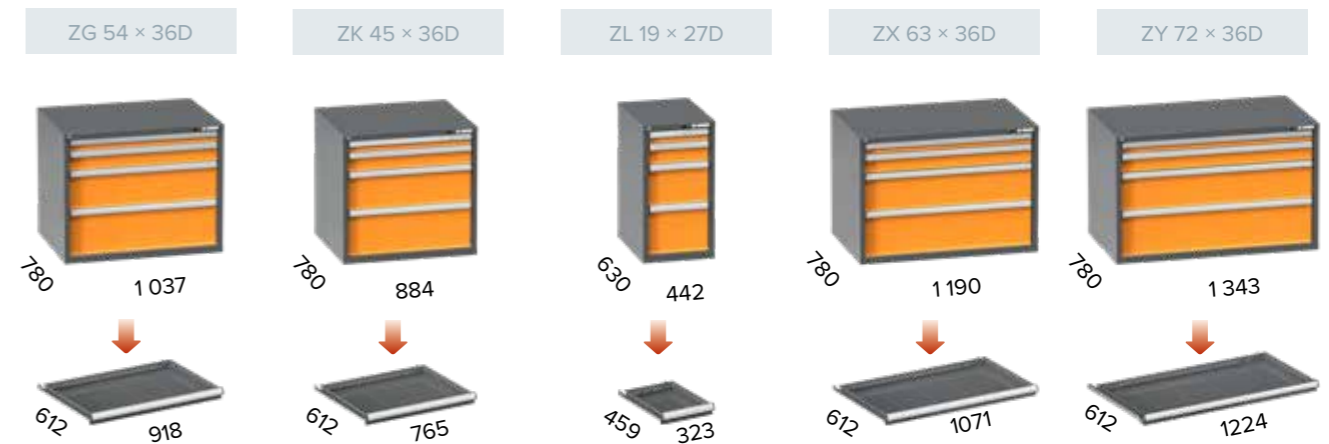



**Standard configuration ZA 27 x 27D**

Standard drawer cabinet equipment: central locking mechanism, drawer blocking, cylindrical lock, ball-bearing full extension with 80 kg load capacity



459 x 459 mm

configurator | 3+ RAL colors | smfu.eu - manual



**Standard configuration ZB 36 x 36D**

Standard drawer cabinet equipment: central locking mechanism, drawer blocking, cylindrical lock, ball-bearing full extension with 80 kg load capacity



612 x 612 mm

configurator | 3+ RAL colors | smfu.eu - manual

Height 840 mm



doors  
750 mm  
2x shelf

Order number	Locking	👤
ZA84-1ESD	cylindrical lock	36



150 E  
300 E  
300 E

Order number	Locking	👤
ZA84-3ESD	cylindrical lock	58
ZA84-3CESD	code lock	58
ZA84-3FESD	chip lock	58



75 E  
100 E  
125 E  
200 E  
250 E

Order number	Locking	👤
ZA84-6ESD	cylindrical lock	69
ZA84-6CESD	code lock	69
ZA84-6FESD	chip lock	69

Height 840 mm



75 E  
125 E  
doors  
550 mm  
1x shelf

Order number	Locking	👤
ZB84-2ESD	cylindrical lock	54



75 E  
100 E  
125 E  
200 E  
250 E

Order number	Locking	👤
ZB84-5ESD	cylindrical lock	78
ZB84-5CESD	code lock	78
ZB84-5FESD	chip lock	78



75 E  
75 E  
100 E  
100 E  
125 E  
125 E  
150 E

Order number	Locking	👤
ZB84-7ESD	cylindrical lock	91
ZB84-7CESD	code lock	91
ZB84-7FESD	chip lock	91

Height 990 mm



100 E  
doors  
800 mm  
2x shelf

Order number	Locking	👤
ZA99-1ESD	cylindrical lock	49



75 E  
100 E  
125 E  
150 E  
150 E  
300 E

Order number	Locking	👤
ZA99-4ESD	cylindrical lock	61
ZA99-4CESD	code lock	61
ZA99-4FESD	chip lock	61



75 E  
75 E  
75 E  
100 E  
100 E  
125 E  
150 E  
200 E

Order number	Locking	👤
ZA99-5ESD	cylindrical lock	94
ZA99-5CESD	code lock	94
ZA99-5FESD	chip lock	94

Height 990 mm



75 E  
125 E  
150 E  
dvířka  
550 mm  
1x police

Order number	Locking	👤
ZB99-2ESD	cylindrical lock	76



75 E  
100 E  
125 E  
150 E  
150 E  
300 E

Order number	Locking	👤
ZB99-4ESD	cylindrical lock	108
ZB99-4CESD	code lock	108
ZB99-4FESD	chip lock	108



75 E  
100 E  
100 E  
125 E  
150 E  
150 E  
200 E

Order number	Locking	👤
ZB99-6ESD	cylindrical lock	115
ZB99-6CESD	code lock	115
ZB99-6FESD	chip lock	115

Height 1215 mm



100 E  
125 E  
300 E  
300 E  
300 E

Order number	Locking	👤
ZA120-3ESD	cylindrical lock	85
ZA120-3CESD	code lock	85
ZA120-3FESD	chip lock	85



75 E  
75 E  
75 E  
100 E  
100 E  
150 E  
150 E  
200 E  
200 E

Order number	Locking	👤
ZA120-4ESD	cylindrical lock	110
ZA120-4CESD	code lock	110
ZA120-4FESD	chip lock	110

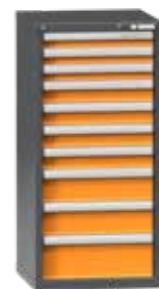

75 E  
75 E  
75 E  
100 E  
100 E  
100 E  
150 E  
150 E  
200 E

Order number	Locking	👤
ZA120-5ESD	cylindrical lock	116
ZA120-5CESD	code lock	116
ZA120-5FESD	chip lock	116

Height 1215 mm



100 E  
125 E  
300 E  
300 E  
300 E

Order number	Locking	👤
ZB120-3ESD	cylindrical lock	109
ZB120-3CESD	code lock	109
ZB120-3FESD	chip lock	109



75 E  
75 E  
75 E  
100 E  
100 E  
150 E  
150 E  
200 E  
200 E

Order number	Locking	👤
ZB120-4ESD	cylindrical lock	143
ZB120-4CESD	code lock	143
ZB120-4FESD	chip lock	143



100 E  
100 E  
125 E  
200 E  
300 E  
300 E

Order number	Locking	👤
ZB120-5ESD	cylindrical lock	118
ZB120-5CESD	code lock	118
ZB120-5FESD	chip lock	118



**Standard configuration ZC 54 x 27D**

Standard drawer cabinet equipment: central locking mechanism, drawer blocking, cylindrical lock, ball-bearing full extension with 80 kg load capacity



918 x 459 mm

Height 840 mm



75 E  
125 E  
250 E  
300 E

Order number	Locking	👤
ZC84-4ESD	cylindrical lock	87
ZC84-4CESD	code lock	87
ZC84-4FESD	chip lock	87



75 E  
100 E  
125 E  
200 E  
250 E

Order number	Locking	👤
ZC84-5ESD	cylindrical lock	95
ZC84-5CESD	code lock	95
ZC84-5FESD	chip lock	95



75 E  
75 E  
100 E  
150 E  
150 E  
200 E

Order number	Locking	👤
ZC84-6ESD	cylindrical lock	104
ZC84-6CESD	code lock	104
ZC84-6FESD	chip lock	104

Height 990 mm



100 E  
doors  
800 mm  
2x shelf

Order number	Locking	👤
ZC99-1ESD	cylindrical lock	67



75 E  
125 E  
150 E  
doors  
550 mm  
1x shelf

Order number	Locking	👤
ZC99-2ESD	cylindrical lock	83



75 E  
100 E  
125 E  
150 E  
150 E  
300 E

Order number	Locking	👤
ZC99-4ESD	cylindrical lock	105
ZC99-4CESD	code lock	105
ZC99-4FESD	chip lock	105

Height 1215 mm



100 E  
125 E  
300 E  
300 E  
300 E

Order number	Locking	👤
ZC120-3ESD	cylindrical lock	116
ZC120-3CESD	code lock	116
ZC120-3FESD	chip lock	116



75 E  
75 E  
75 E  
100 E  
100 E  
150 E  
200 E  
200 E

Order number	Locking	👤
ZC120-4ESD	cylindrical lock	149
ZC120-4CESD	code lock	149
ZC120-4FESD	chip lock	149



75 E  
100 E  
100 E  
200 E  
200 E  
200 E  
250 E

Order number	Locking	👤
ZC120-5ESD	cylindrical lock	132
ZC120-5CESD	code lock	132
ZC120-5FESD	chip lock	132



**Standard configuration ZD 36 x 27D**

Standard drawer cabinet equipment: central locking mechanism, drawer blocking, cylindrical lock, ball-bearing full extension with 80 kg load capacity



612 x 459 mm

Height 840 mm



75 E  
125 E  
dvířka  
550 mm  
1x police

Order number	Locking	👤
ZD84-2ESD	cylindrical lock	62



75 E  
100 E  
125 E  
200 E  
250 E

Order number	Locking	👤
ZD84-5ESD	cylindrical lock	89
ZD84-5CESD	code lock	89
ZD84-5FESD	chip lock	89



75 E  
75 E  
100 E  
150 E  
150 E  
200 E

Order number	Locking	👤
ZD84-6ESD	cylindrical lock	100
ZD84-6CESD	code lock	100
ZD84-6FESD	chip lock	100

Height 990 mm



100 E  
doors  
800 mm  
2x shelf

Order number	Locking	👤
ZD99-1ESD	cylindrical lock	53



75 E  
100 E  
125 E  
150 E  
150 E  
300 E

Order number	Locking	👤
ZD99-4ESD	cylindrical lock	93
ZD99-4CESD	code lock	93
ZD99-4FESD	chip lock	93



75 E  
100 E  
100 E  
125 E  
150 E  
150 E  
200 E

Order number	Locking	👤
ZD99-6ESD	cylindrical lock	99
ZD99-6CESD	code lock	99
ZD99-6FESD	chip lock	99

Height 1215 mm



75 E  
75 E  
75 E  
100 E  
100 E  
doors  
800 mm  
2x shelf

Order number	Locking	👤
ZD120-1ESD	cylindrical lock	84



75 E  
75 E  
75 E  
100 E  
100 E  
150 E  
150 E  
200 E  
200 E

Order number	Locking	👤
ZD120-4ESD	cylindrical lock	122
ZD120-4CESD	code lock	122
ZD120-4FESD	chip lock	122



100 E  
100 E  
125 E  
200 E  
300 E  
300 E

Order number	Locking	👤
ZD120-5ESD	cylindrical lock	102
ZD120-5CESD	code lock	102
ZD120-5FESD	chip lock	102



**Standard configuration ZE 27 x 36D**

Standard drawer cabinet equipment: central locking mechanism, drawer blocking, cylindrical lock, ball-bearing full extension with 80 kg load capacity

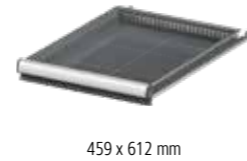

Height 840 mm



Order number	Locking	Person icon
ZE84-1ESD	cylindrical lock	41



Order number	Locking	Person icon
ZE84-6ESD	cylindrical lock	88
ZE84-6CESD	code lock	88
ZE84-6FESD	chip lock	88



Order number	Locking	Person icon
ZE84-7ESD	cylindrical lock	95
ZE84-7CESD	code lock	95
ZE84-7FESD	chip lock	95

Height 990 mm



Order number	Locking	Person icon
ZE99-2ESD	cylindrical lock	70



Order number	Locking	Person icon
ZE99-5ESD	cylindrical lock	81
ZE99-5CESD	code lock	81
ZE99-5FESD	chip lock	81



Order number	Locking	Person icon
ZE99-6ESD	cylindrical lock	103
ZE99-6CESD	code lock	103
ZE99-6FESD	chip lock	103

Height 1215 mm



Order number	Locking	Person icon
ZE120-2ESD	cylindrical lock	93



Order number	Locking	Person icon
ZE120-4ESD	cylindrical lock	130
ZE120-4CESD	code lock	130
ZE120-4FESD	chip lock	130



Order number	Locking	Person icon
ZE120-5ESD	cylindrical lock	105
ZE120-5CESD	code lock	105
ZE120-5FESD	chip lock	105



**Standard configuration ZG 54 x 36D**

Standard drawer cabinet equipment: central locking mechanism, drawer blocking, cylindrical lock, ball-bearing full extension with 80 kg load capacity

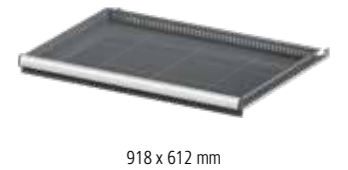

Height 840 mm



Order number	Locking	Person icon
ZG84-2ESD	cylindrical lock	101
ZG84-2CESD	code lock	101
ZG84-2FESD	chip lock	101



Order number	Locking	Person icon
ZG84-5ESD	cylindrical lock	132
ZG84-5CESD	code lock	132
ZG84-5FESD	chip lock	132



Order number	Locking	Person icon
ZG84-7ESD	cylindrical lock	153
ZG84-7CESD	code lock	153
ZG84-7FESD	chip lock	153

Height 990 mm



Order number	Locking	Person icon
ZG99-3ESD	cylindrical lock	132
ZG99-3CESD	code lock	132
ZG99-3FESD	chip lock	132



Order number	Locking	Person icon
ZG99-4ESD	cylindrical lock	140
ZG99-4CESD	code lock	140
ZG99-4FESD	chip lock	140



Order number	Locking	Person icon
ZG99-5ESD	cylindrical lock	151
ZG99-5CESD	code lock	151
ZG99-5FESD	chip lock	151

Height 1215 mm



Order number	Locking	Person icon
ZG120-3ESD	cylindrical lock	163
ZG120-3CESD	code lock	163
ZG120-3FESD	chip lock	163



Order number	Locking	Person icon
ZG120-4ESD	cylindrical lock	173
ZG120-4CESD	code lock	173
ZG120-4FESD	chip lock	173



Order number	Locking	Person icon
ZG120-5ESD	cylindrical lock	183
ZG120-5CESD	code lock	183
ZG120-5FESD	chip lock	183



**Standard configuration ZK 45 x 36D**

Standard drawer cabinet equipment: central locking mechanism, drawer blocking, cylindrical lock, ball-bearing full extension with 80 kg load capacity

- configurator
- 3+ RAL colors
- smfu.eu - manual



765 x 612 mm

Height 840 mm



75 E  
125 E  
doors  
550 mm  
1x shelf

Order number	Locking	Person icon
ZK84-2ESD	cylindrical lock	69



150 E  
300 E  
300 E

Order number	Locking	Person icon
ZK84-3ESD	cylindrical lock	83
ZK84-3CESD	code lock	83
ZK84-3FESD	chip lock	83



75 E  
100 E  
125 E  
200 E  
250 E

Order number	Locking	Person icon
ZK84-5ESD	cylindrical lock	100
ZK84-5CESD	code lock	100
ZK84-5FESD	chip lock	100

Height 990 mm



75 E  
125 E  
150 E  
doors  
550 mm  
1x shelf

Order number	Locking	Person icon
ZK99-2ESD	cylindrical lock	87



100 E  
100 E  
100 E  
300 E  
300 E

Order number	Locking	Person icon
ZK99-3ESD	cylindrical lock	110
ZK99-3CESD	code lock	110
ZK99-3FESD	chip lock	110



75 E  
100 E  
100 E  
125 E  
150 E  
150 E  
200 E

Order number	Locking	Person icon
ZK99-6ESD	cylindrical lock	128
ZK99-6CESD	code lock	128
ZK99-6FESD	chip lock	128

Height 1215 mm



75 E  
100 E  
125 E  
125 E  
150 E  
doors  
550 mm  
1x shelf

Order number	Locking	Person icon
ZK120-2ESD	cylindrical lock	116



75 E  
75 E  
75 E  
100 E  
100 E  
150 E  
150 E  
200 E  
200 E

Order number	Locking	Person icon
ZK120-4ESD	cylindrical lock	158
ZK120-4CESD	code lock	158
ZK120-4FESD	chip lock	158



100 E  
100 E  
125 E  
150 E  
200 E  
300 E  
300 E

Order number	Locking	Person icon
ZK120-5ESD	cylindrical lock	130
ZK120-5CESD	code lock	130
ZK120-5FESD	chip lock	130



**Standard configuration ZL 19 x 27D**

Standard drawer cabinet equipment: central locking mechanism, drawer blocking, cylindrical lock, ball-bearing full extension with 80 kg load capacity

- configurator
- 3+ RAL colors
- smfu.eu - manual



323 x 459 mm

Height 840 mm



75 E  
125 E  
doors  
550 mm  
1x shelf

Order number	Locking	Person icon
ZL84-2ESD	cylindrical lock	47



75 E  
125 E  
250 E  
300 E

Order number	Locking	Person icon
ZL84-4ESD	cylindrical lock	56
ZL84-4CESD	code lock	56
ZL84-4FESD	chip lock	56



75 E  
75 E  
100 E  
150 E  
150 E  
200 E

Order number	Locking	Person icon
ZL84-7ESD	cylindrical lock	67
ZL84-7CESD	code lock	67
ZL84-7FESD	chip lock	67

Height 990 mm



100 E  
doors  
800 mm  
2x shelf

Order number	Locking	Person icon
ZL99-1ESD	cylindrical lock	43



75 E  
125 E  
150 E  
doors  
550 mm  
1x shelf

Order number	Locking	Person icon
ZL99-2ESD	cylindrical lock	54



75 E  
100 E  
100 E  
125 E  
150 E  
150 E  
200 E

Order number	Locking	Person icon
ZL99-6ESD	cylindrical lock	79
ZL99-6CESD	code lock	79
ZL99-6FESD	chip lock	79

Height 1215 mm



75 E  
100 E  
125 E  
125 E  
150 E  
doors  
550 mm  
1x shelf

Order number	Locking	Person icon
ZL120-2ESD	cylindrical lock	72



75 E  
75 E  
75 E  
100 E  
100 E  
150 E  
150 E  
200 E  
200 E

Order number	Locking	Person icon
ZL120-4ESD	cylindrical lock	97
ZL120-4CESD	code lock	97
ZL120-4FESD	chip lock	97



100 E  
100 E  
125 E  
200 E  
300 E  
300 E

Order number	Locking	Person icon
ZL120-6ESD	cylindrical lock	81
ZL120-6CESD	code lock	81
ZL120-6FESD	chip lock	81



**Standard configuration ZX 63 x 36D**

Standard drawer cabinet equipment: central locking mechanism, drawer blocking, cylindrical lock, ball-bearing full extension with 80 kg load capacity



1071 x 612 mm

780 mm  
1190 mm



**Standard configuration ZY 72 x 36D**

Standard drawer cabinet equipment: central locking mechanism, drawer blocking, cylindrical lock, ball-bearing full extension with 80 kg load capacity



1224 x 612 mm

780 mm  
1343 mm

Height 840 mm



75 E  
100 E  
100 E  
150 E  
200 E

Order number	Locking	👤
ZX84-4ESD	cylindrical lock	102
ZX84-4CESD	code lock	102
ZX84-4FESD	chip lock	102



75 E  
75 E  
100 E  
100 E  
125 E  
125 E  
150 E

Order number	Locking	👤
ZX84-5ESD	cylindrical lock	143
ZX84-5CESD	code lock	143
ZX84-5FESD	chip lock	143



75 E  
75 E  
75 E  
75 E  
75 E  
75 E  
100 E  
100 E  
100 E

Order number	Locking	👤
ZX84-7ESD	cylindrical lock	165
ZX84-7CESD	code lock	165
ZX84-7FESD	chip lock	165

Height 840 mm



75 E  
100 E  
100 E  
150 E  
200 E

Order number	Locking	👤
ZY84-4ESD	cylindrical lock	145
ZY84-4CESD	code lock	145
ZY84-4FESD	chip lock	145



75 E  
75 E  
100 E  
100 E  
125 E  
125 E  
150 E

Order number	Locking	👤
ZY84-5ESD	cylindrical lock	181
ZY84-5CESD	code lock	181
ZY84-5FESD	chip lock	181



75 E  
75 E  
75 E  
75 E  
75 E  
100 E  
100 E  
100 E

Order number	Locking	👤
ZY84-7ESD	cylindrical lock	213
ZY84-7CESD	code lock	213
ZY84-7FESD	chip lock	213

Height 990 mm



75 E  
100 E  
125 E  
150 E  
150 E  
300 E

Order number	Locking	👤
ZX99-3ESD	cylindrical lock	141
ZX99-3CESD	code lock	141
ZX99-3FESD	chip lock	141



75 E  
100 E  
100 E  
100 E  
125 E  
150 E  
150 E  
200 E

Order number	Locking	👤
ZX99-4ESD	cylindrical lock	151,8
ZX99-4CESD	code lock	151,8
ZX99-4FESD	chip lock	151,8



75 E  
75 E  
100 E  
100 E  
100 E  
100 E  
125 E  
150 E  
150 E  
200 E

Order number	Locking	👤
ZX99-5ESD	cylindrical lock	169,9
ZX99-5CESD	code lock	169,9
ZX99-5FESD	chip lock	169,9

Height 990 mm



75 E  
100 E  
125 E  
150 E  
150 E  
300 E

Order number	Locking	👤
ZY99-3ESD	cylindrical lock	174
ZY99-3CESD	code lock	174
ZY99-3FESD	chip lock	174



75 E  
100 E  
100 E  
100 E  
125 E  
150 E  
150 E  
200 E

Order number	Locking	👤
ZY99-4ESD	cylindrical lock	190
ZY99-4CESD	code lock	190
ZY99-4FESD	chip lock	190



75 E  
75 E  
100 E  
100 E  
100 E  
100 E  
150 E  
150 E  
200 E

Order number	Locking	👤
ZY99-5ESD	cylindrical lock	200
ZY99-5CESD	code lock	200
ZY99-5FESD	chip lock	200

Height 1215 mm



100 E  
100 E  
125 E  
200 E  
300 E  
300 E

Order number	Locking	👤
ZX120-2ESD	cylindrical lock	154,8
ZX120-2CESD	code lock	154,8
ZX120-2FESD	chip lock	154,8



75 E  
75 E  
75 E  
75 E  
100 E  
100 E  
100 E  
150 E  
150 E  
200 E  
200 E

Order number	Locking	👤
ZX120-4ESD	cylindrical lock	187,6
ZX120-4CESD	code lock	187,6
ZX120-4FESD	chip lock	187,6



75 E  
75 E  
75 E  
100 E  
100 E  
100 E  
100 E  
100 E  
150 E  
200 E  
200 E

Order number	Locking	👤
ZX120-5ESD	cylindrical lock	198,3
ZX120-5CESD	code lock	198,3
ZX120-5FESD	chip lock	198,3

Height 1215 mm



100 E  
100 E  
125 E  
200 E  
300 E  
300 E

Order number	Locking	👤
ZY120-2ESD	cylindrical lock	188
ZY120-2CESD	code lock	188
ZY120-2FESD	chip lock	188



75 E  
75 E  
75 E  
100 E  
100 E  
100 E  
150 E  
150 E  
200 E  
200 E

Order number	Locking	👤
ZY120-4ESD	cylindrical lock	236
ZY120-4CESD	code lock	236
ZY120-4FESD	chip lock	236



75 E  
75 E  
75 E  
100 E  
100 E  
100 E  
100 E  
150 E  
150 E  
200 E  
200 E

Order number	Locking	👤
ZY120-5ESD	cylindrical lock	252
ZY120-5CESD	code lock	252
ZY120-5FESD	chip lock	252



### Standard configuration MAX

Standard drawer cabinet equipment: central locking mechanism, drawer blocking, cylindrical lock, full extension with 80 kg load capacity, plinth – front removable panel.



612 x 612 mm  
918 x 612 mm



configurator



3+ RAL colors



smfu.eu - manual



You can change the drawer layout or the number of shelves thanks to the custom configuration of the cabinet. Select an empty housing and then equip it with any number of drawers, doors, and shelves.



Shelves and doors are intended only for the upper part of the cabinet; drawers are for the lower part of the cabinet.

### ZB MAX width 731 mm



doors  
800 mm  
1x shelf  
  
100 E  
200 E  
300 E  
300 E

Order number	Locking	kg
ZBmax-1ESD	cylindrical lock	125



doors  
800 mm  
1x shelf  
  
75 E  
100 E  
125 E  
150 E  
150 E  
300 E

Order number	Locking	kg
ZBmax-2ESD	cylindrical lock	144



1x shelf  
  
75 E  
100 E  
125 E  
150 E  
150 E  
300 E

Order number	Locking	kg
ZBmax-3ESD	cylindrical lock	138

### ZG MAX šířka 1037 mm



doors  
800 mm  
1x shelf  
  
100 E  
100 E  
100 E  
300 E  
300 E

Order number	Locking	kg
ZGmax-1ESD	cylindrical lock	158



doors  
800 mm  
1x shelf  
  
100 E  
100 E  
150 E  
150 E  
150 E  
250 E

Order number	Locking	kg
ZGmax-2ESD	cylindrical lock	177



1x shelf  
  
100 E  
100 E  
150 E  
150 E  
150 E  
250 E

Order number	Locking	kg
ZGmax-3ESD	cylindrical lock	169

### Custom configuration ZB MAX



#### Drawers

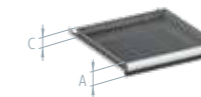

Front height A mm	Front height C mm	Order number	kg
75	50	ZBE75ESD	10,1
100	75	ZBE100ESD	10,7
125	75	ZBE125ESD	11,0
150	125	ZBE150ESD	11,9
200	175	ZBE200ESD	13,1
250	175	ZBE250ESD	13,6
300	275	ZBE300ESD	15,4

Full extension  
80 kg

Order number	kg
ZBE75ESD	10,1
ZBE100ESD	10,7
ZBE125ESD	11,0
ZBE150ESD	11,9
ZBE200ESD	13,1
ZBE250ESD	13,6
ZBE300ESD	15,4

#### Power rail

Socket type	Order number	W x H x D
E (CZ)	EZS36M	657 x 123 x 66
F (DE)	EZS36FM	657 x 123 x 66

#### Cabinet body

Order number	Locking	kg	kg
ZBmax-KESD	cylindrical lock	62	600

#### Shelf

Order number	W x D mm	kg	kg
VP3636ESD	717 x 665	4,9	50

The shelf can only be installed in the upper part of the cabinet.

#### Doors

Order number	Height S mm
D36-800ESD	800

The door can only be installed in the upper part of the cabinet.

#### Extension lead

Socket type	Order number	W x H x D
E (CZ)	PPZS36M	657 x 73 x 34
F (DE)	PPZS36FM	657 x 73 x 34



When equipping a drawer cabinet with an electric strip or extension cord, the maximum number of drawers is reduced.

123 mm  
= zásuvka



### Custom configuration ZG MAX



#### Drawers

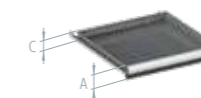

Front height A mm	Front height C mm	Order number	kg
75	50	ZGE75ESD	12,3
100	75	ZGE100ESD	13,1
125	75	ZGE125ESD	13,5
150	125	ZGE150ESD	14,7
200	175	ZGE200ESD	16,2
250	175	ZGE250ESD	16,9
300	275	ZGE300ESD	19,3

Full extension  
80 kg

Order number	kg
ZGE75ESD	12,3
ZGE100ESD	13,1
ZGE125ESD	13,5
ZGE150ESD	14,7
ZGE200ESD	16,2
ZGE250ESD	16,9
ZGE300ESD	19,3

#### Cabinet body

Order number	Locking	kg	kg
ZGmax-KESD	cylindrical lock	76	600

#### Shelf

Order number	W x D mm	kg	kg
VP5436ESD	1023 x 665	6,7	50

The shelf can only be installed in the upper part of the cabinet.

#### Doors

Order number	Height S mm
D54-800ESD	800

The door can only be installed in the upper part of the cabinet.



On page 39, you will find the drawer partition material.



**Standard configuration ZA 27 x 27D**

Standard equipment of mobile container ZA: central locking mechanism, drawer blocking, cylindrical lock, ball-bearing full extension with 80 kg load capacity, drawer safety catches, 100 mm wheels, handles, raised edge



459 x 459 mm



1x shelf  
35 kg

Order number	Locking	Person	Weight
ZAMP-1ESD	-	20	50

Total height 785 mm  
2x wheel KPESD 100 mm  
2x wheel KPOBESD 100 mm



100 E  
100 E  
100 E  
1x shelf  
35 kg

Order number	Locking	Person	Weight
ZAM39-1ESD	cylindrical lock	95	100

Total height 785 mm  
2x wheel KPESD 100 mm  
2x wheel KPOBESD 100 mm



75 E  
75 E  
100 E  
200 E

Order number	Locking	Person	Weight
ZAM59-2ESD	cylindrical lock	111	300

Total height 785 mm  
2x wheel KPESD 100 mm  
2x wheel KPOBESD 100 mm



**Standard configuration ZB 36 x 36D**

Standard equipment of mobile container ZB: central locking mechanism, drawer blocking, cylindrical lock, ball-bearing full extension with 80 kg load capacity, drawer safety catches, 125 mm wheels, handles, raised edge



612 x 612 mm



1x shelf  
35 kg

Order number	Locking	Person	Weight
ZBMP-1ESD	-	32	50

Total height 810 mm  
2x wheel KPESD 125 mm  
2x wheel KPOBESD 125 mm



100 E  
100 E  
100 E  
1x shelf  
35 kg

Order number	Locking	Person	Weight
ZBM39-1ESD	cylindrical lock	95	100

Total height 810 mm  
2x wheel KPESD 125 mm  
2x wheel KPOBESD 125 mm



75 E  
100 E  
125 E  
200 E  
250 E

Order number	Locking	Person	Weight
ZBM84-1ESD	cylindrical lock	111	300

Total height 1060 mm  
2x wheel KPESD 125 mm  
2x wheel KPOBESD 125 mm



**Standard configuration ZC 54 x 27D**

Standard equipment of mobile container ZC: central locking mechanism, drawer blocking, cylindrical lock, ball-bearing full extension with 80 kg load capacity, drawer safety catches, 125 mm wheels, handles, raised edge



459 x 918 mm



75 E  
125 E  
300 E

Order number	Locking	Person	Weight
ZCM59-1ESD	cylindrical lock	81	400

Total height 855 mm  
2x wheel KPESD 125 mm  
2x wheel KPOBESD 125 mm



75 E  
100 E  
125 E  
300 E

Order number	Locking	Person	Weight
ZCM69-1ESD	cylindrical lock	95	400

Total height 955 mm  
2x wheel KPESD 125 mm  
2x wheel KPOBESD 125 mm



75 E  
100 E  
125 E  
200 E  
250 E

Order number	Locking	Person	Weight
ZCM84-1ESD	cylindrical lock	111	400

Total height 1105 mm  
2x wheel KPESD 125 mm  
2x wheel KPOBESD 125 mm



**Standard configuration ZD 36 x 27D**

Standard equipment of mobile container ZD: central locking mechanism, drawer blocking, cylindrical lock, ball-bearing full extension with 80 kg load capacity, drawer safety catches, 125 mm wheels, handles, raised edge



459 x 612 mm



75 E  
100 E  
125 E  
200 E

Order number	Locking	Person	Weight
ZDM59-2ESD	cylindrical lock	70	300

Total height 810 mm  
2x wheel KPESD 125 mm  
2x wheel KPOBESD 125 mm



75 E  
100 E  
125 E  
300 E

Order number	Locking	Person	Weight
ZDM69-1ESD	cylindrical lock	74	300

Total height 910 mm  
2x wheel KPESD 125 mm  
2x wheel KPOBESD 125 mm



75 E  
100 E  
125 E  
200 E  
250 E

Order number	Locking	Person	Weight
ZDM84-1ESD	cylindrical lock	87	400

Total height 1060 mm  
2x wheel KPESD 125 mm  
2x wheel KPOBESD 125 mm



**Standard configuration ZE 27 x 36D**

Standard equipment of mobile container ZE: central locking mechanism, drawer blocking, cylindrical lock, ball-bearing full extension with 80 kg load capacity, drawer safety catches, 125 mm wheels, handles, raised edge

- configurator
- 3+ RAL colors
- smfu.eu - manual

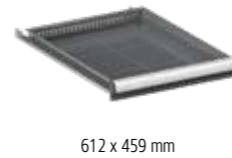

75 E  
100 E  
125 E  
200 E

Order number	Locking	Person icon	Wheel icon
ZEM59-2ESD	cylindrical lock	73	300

Total height 810 mm  
2x wheel KPESD 125 mm  
2x wheel KPOBESD 125 mm



75 E  
100 E  
125 E  
300 E

Order number	Locking	Person icon	Wheel icon
ZEM69-1ESD	cylindrical lock	78	300

Total height 910 mm  
2x wheel KPESD 125 mm  
2x wheel KPOBESD 125 mm



75 E  
100 E  
125 E  
200 E  
250 E

Order number	Locking	Person icon	Wheel icon
ZEM84-1ESD	cylindrical lock	91	300

Total height 1060 mm  
2x wheel KPESD 125 mm  
2x wheel KPOBESD 125 mm



**Standard configuration ZG 54 x 36D**

Standard equipment of mobile container ZG: central locking mechanism, drawer blocking, cylindrical lock, ball-bearing full extension with 80 kg load capacity, drawer safety catches, 125 mm wheels, handles, raised edge

- configurator
- 3+ RAL colors
- smfu.eu - manual

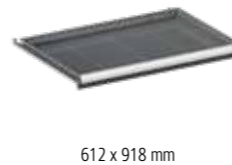

75 E  
125 E  
300 E

Order number	Locking	Person icon	Wheel icon
ZGM59-1ESD	cylindrical lock	89	400

Total height 855 mm  
2x wheel KPESD 125 mm  
2x wheel KPOBESD 125 mm



75 E  
100 E  
125 E  
300 E

Order number	Locking	Person icon	Wheel icon
ZGM69-1ESD	cylindrical lock	105	400

Total height 955 mm  
2x wheel KPESD 125 mm  
2x wheel KPOBESD 125 mm



75 E  
100 E  
125 E  
200 E  
250 E

Order number	Locking	Person icon	Wheel icon
ZGM84-1ESD	cylindrical lock	129	400

Total height 1105 mm  
2x wheel KPESD 125 mm  
2x wheel KPOBESD 125 mm



**Standard configuration ZK 45 x 36D**

Standard equipment of mobile container ZK: central locking mechanism, drawer blocking, cylindrical lock, ball-bearing full extension with 80 kg load capacity, drawer safety catches, 125 mm wheels, handles, raised edge

- configurator
- 3+ RAL colors
- smfu.eu - manual



100 E  
100 E  
100 E  
1x shelf  
35 kg

Order number	Locking	Person icon	Wheel icon
ZKM39-1ESD	cylindrical lock	75	100

Total height 855 mm  
2x wheel KPESD 125 mm  
2x wheel KPOBESD 125 mm



75 E  
125 E  
300 E

Order number	Locking	Person icon	Wheel icon
ZKM59-1ESD	cylindrical lock	78	400

Total height 855 mm  
2x wheel KPESD 125 mm  
2x wheel KPOBESD 125 mm



75 E  
100 E  
125 E  
200 E  
250 E

Order number	Locking	Person icon	Wheel icon
ZKM84-1ESD	cylindrical lock	109	400

Total height 1105 mm  
2x wheel KPESD 125 mm  
2x wheel KPOBESD 125 mm



**Standard configuration ZL 19 x 27D**

Standard equipment of mobile container ZL: central locking mechanism, drawer blocking, cylindrical lock, ball-bearing full extension with 80 kg load capacity, drawer safety catches, 100 mm wheels, handles, raised edge

- configurator
- 3+ RAL colors
- smfu.eu - manual

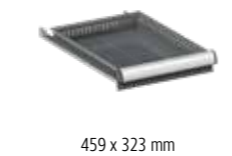

1x shelf  
35 kg

Order number	Locking	Person icon	Wheel icon
ZLMP-1ESD	-	23	50

Total height 785 mm  
2x wheel KPESD 100 mm  
2x wheel KPOBESD 100 mm



100 E  
100 E  
100 E

Order number	Locking	Person icon	Wheel icon
ZLM39-1ESD	cylindrical lock	45	100

Total height 785 mm  
2x wheel KPESD 100 mm  
2x wheel KPOBESD 100 mm



75 E  
75 E  
100 E  
250 E

Order number	Locking	Person icon	Wheel icon
ZLM59-2ESD	cylindrical lock	56	300

Total height 785 mm  
2x wheel KPESD 100 mm  
2x wheel KPOBESD 100 mm

## Custom configuration

### How to set up a custom configuration of a drawer cabinet

- Choose the dimensions of the cabinet body.
- Choose the number of drawers so that the sum of front heights A (or doors) equals the clear opening of the cabinet body S.
- Choose the color (RAL 7016, RAL 7035, and RAL 1028).
- Choose accessories.
- Choose drawer partition material.



### 1 Cabinet body dimensions

Select the appropriate cabinet body size according to your needs. There are 10 footprints and 8 heights available.

Dimension H = total height of the cabinet body

Dimension S = clear opening of the cabinet body

#### Locking

Standardly, the cabinet body is equipped with a cylindrical lock. You can choose a code lock (order number + „C“) or a chip lock (order number + „P“). In such cases, remember to add the relevant letter to the order code of the selected cabinet body.



When ordering a cabinet body with a code or chip lock, it can only be equipped with drawers – the cabinet body cannot be combined with doors. Mobile containers cannot be equipped with an electronic lock.

Footprints of cabinet bodies:

Type	W x D mm
ZA 27 x 27D	578 x 630
ZB 36 x 36D	731 x 780
ZC 54 x 27D	1037 x 630
ZD 36 x 27D	731 x 630
ZE 27 x 36D	578 x 780
ZG 54 x 36D	1037 x 780
ZK 45 x 36D	884 x 780
ZL 19 x 27D	442 x 630
ZX 63 x 36D	1190 x 780
ZY 72 x 36D	1343 x 780

Height of cabinet bodies:

Dimension H mm	Dimension S mm
190 *	100 *
390	300
590	500
690	600
740	650
840	750
990	900
1215	1125
1415	1325

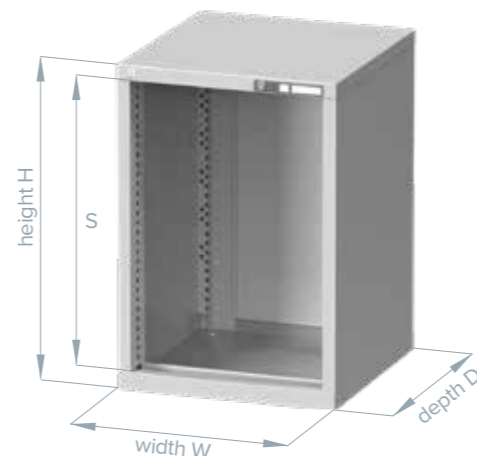

\* Height of cabinet body 190 mm is available only for footprints ZA and ZB and is intended for hanging under a table.

### 2 Drawers

Choose the composition of drawers / doors for the drawer cabinet. The clear opening of the cabinet body S must equal the sum of heights A of the selected drawers or doors. We recommend subtracting the dimensions of front heights A from value S sequentially. The drawer size marked as C determines the side wall height, which is important for choosing metal partition material for the drawer.

For all offered cabinet bodies, there are 7 drawer heights available. The drawer full extension design ensures 100% opening with a load capacity of 80 kg.

#### Drawer safety catch (order number + „P“)

A safety element that prevents spontaneous opening of the drawer. In case of ordering a mobile container, add the letter „P“ after the order code of the selected drawer.

Front heights:



### 3 Doors / doors with threshold

If you choose a cabinet only with doors, the clear opening dimension of the cabinet body S must equal the door height. In case of a combination of drawers and doors, the clear opening dimension of the cabinet body S must equal the height of the doors with a sill plus the sum of heights A of the selected drawers. For combination with drawers, always choose doors with a sill; doors without a sill cannot be combined with drawers.

There are 4 door heights or doors with a sill available. For wide cabinet bodies, the doors are supplied in a double-wing version.

### 4 Wheels

Choose the appropriate wheel diameter – 100 mm or 125 mm. The set for a mobile container includes a metal reinforcement and always one pair of fixed wheels and one pair of swivel wheels with brakes. Wheels are manufactured in an antistatic version.



### 5 Accessories



#### Internal shelf

Load capacity 50 kg, thanks to the perforation of the walls, it is height-adjustable by 50 mm. Finished with ESD paint.



#### Drawer partition - boxes

Manufactured in several footprints (153 x 153 mm and three heights) from antistatic plastic (ABS dissipative).



#### Raised edge

Three-sided sheet metal edge, height 20 mm, with loosely placed ESD rubber mat. Cannot be ordered separately later.



#### Drawer partition - trays

Manufactured in several footprints (153 x 153 mm and three heights) from antistatic plastic (ABS dissipative).



#### Plinth

Height 100 mm, includes 2 removable front panels.



Suitable metal drawer partition material can be found on page 45.

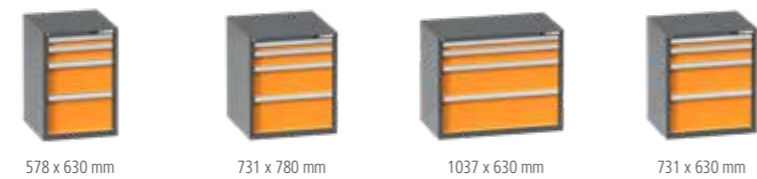

1 Cabinet body

Cabinet bodies

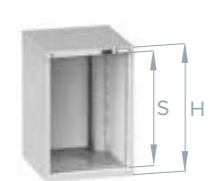

Chip lock (code + F)



Code lock (code + C)

Cabinet bodies	Height S mm	Height H mm	ZA 27 x 27D		ZB 36 x 36D		ZC 54 x 27D		ZD 36 x 27D	
			Order number	kg	Order number	kg	Order number	kg	Order number	kg
	100	190	ZAK19ESD	10/150	ZBK19ESD	13/150	-	-	-	-
	300	390	ZAK39ESD	16/250	ZBK39ESD	21/250	ZCK39ESD	23/250	ZDK39ESD	18/250
	500	590	ZAK59ESD	20/450	ZBK59ESD	25/450	ZCK59ESD	27/450	ZDK59ESD	22/450
	600	690	ZAK69ESD	22/450	ZBK69ESD	27/450	ZCK69ESD	30/450	ZDK69ESD	24/450
	650	740	ZAK74ESD	24/700	ZBK74ESD	30/700	ZCK74ESD	32/700	ZDK74ESD	26/700
	750	840	ZAK84ESD	26/700	ZBK84ESD	32/700	ZCK84ESD	34/700	ZDK84ESD	28/700
	900	990	ZAK99ESD	30/700	ZBK99ESD	36/700	ZCK99ESD	38/700	ZDK99ESD	32/700
	1125	1215	ZAK120ESD	34/700	ZBK120ESD	41/700	ZCK120ESD	43/700	ZDK120ESD	37/700
	1325	1415	ZAK140ESD	38/700	ZBK140ESD	46/700	ZCK140ESD	48/700	ZDK140ESD	41/700

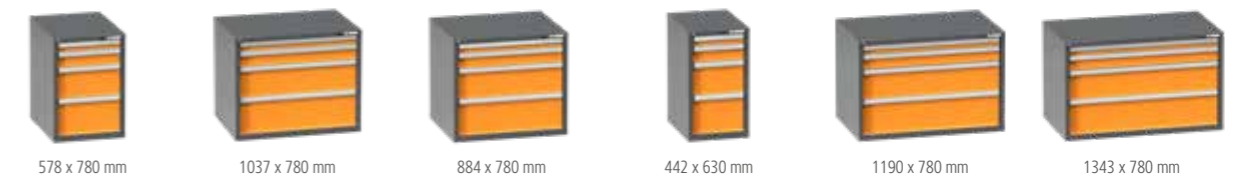

ZE 27 x 36D		ZG 54 x 36D		ZK 45 x 36D		ZL 19 x 27D		ZX 63 x 36D		ZY 72 x 36D	
Order number	kg	Order number	kg	Order number	kg	Order number	kg	Order number	kg	Order number	kg
-	-	-	-	-	-	-	-	-	-	-	-
ZEK39ESD	18/250	ZGK39ESD	25/250	ZKK39ESD	22/250	ZLK39ESD	14/250	-	-	-	-
ZEK59ESD	23/450	ZGK59ESD	31/450	ZKK59ESD	28/450	ZLK59ESD	18/450	-	-	-	-
ZEK69ESD	24/450	ZGK69ESD	33/450	ZKK69ESD	30/450	ZLK69ESD	20/450	-	-	-	-
ZEK74ESD	27/700	ZGK74ESD	35/700	ZKK74ESD	32/700	ZLK74ESD	22/700	-	-	-	-
ZEK84ESD	29/700	ZGK84ESD	38/700	ZKK84ESD	35/700	ZLK84ESD	24/700	ZXK84ESD	41/700	ZYK84ESD	41/700
ZEK99ESD	33/700	ZGK99ESD	42/700	ZKK99ESD	39/700	ZLK99ESD	27/700	ZXK99ESD	45/700	ZYK99ESD	48/700
ZEK120ESD	38/700	ZGK120ESD	48/700	ZKK120ESD	45/700	ZLK120ESD	32/700	ZXK120ESD	51/700	ZYK120ESD	54/700
ZEK140ESD	42/700	ZGK140ESD	53/700	ZKK140ESD	49/700	ZLK140ESD	35/700	-	-	-	-



In the case of ordering a cabinet body with a code or chip lock, this cabinet body can only be equipped with drawers – the cabinet body cannot be combined with doors. Mobile containers cannot be equipped with an electronic lock.

2 Doors / Threshold Doors

Doors

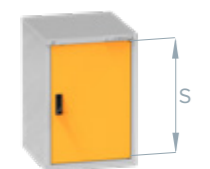

Doors	Height S mm	ZA 27 x 27D	ZB 36 x 36D	ZC 54 x 27D	ZD 36 x 27D
		Order number	Order number	Order number	Order number
	500	D27-500ESD	D36-500ESD	D54-500ESD	D36-500ESD
	600	D27-600ESD	D36-600ESD	D54-600ESD	D36-600ESD
	650	D27-650ESD	D36-650ESD	D54-650ESD	D36-650ESD
	750	D27-750ESD	D36-750ESD	D54-750ESD	D36-750ESD

The technical design of the doors allows for the opening direction to be changed from right-handed to left-handed.

Threshold doors



Threshold doors	Height S mm	ZA 27 x 27D	ZB 36 x 36D	ZC 54 x 27D	ZD 36 x 27D
		Order number	Order number	Order number	Order number
	500 + 50 Threshold	DP27-550ESD	DP36-550ESD	DP54-550ESD	DP36-550ESD
	600 + 50 Threshold	DP27-650ESD	DP36-650ESD	DP54-650ESD	DP36-650ESD
	650 + 50 Threshold	DP27-700ESD	DP36-700ESD	DP54-700ESD	DP36-700ESD
	750 + 50 Threshold	DP27-800ESD	DP36-800ESD	DP54-800ESD	DP36-800ESD

The technical design of the doors allows for the opening direction to be changed from right-handed to left-handed.

ZE 27 x 36D	ZG 54 x 36D	ZK 45 x 36D	ZL 19 x 27D	ZX 63 x 36D	ZY 72 x 36D
Order number	Order number	Order number	Order number	Order number	Order number
D27-500ESD	D54-500ESD	D45-500ESD	D19-500ESD	-	-
D27-600ESD	D54-600ESD	D45-600ESD	D19-600ESD	-	-
D27-650ESD	D54-650ESD	D45-650ESD	D19-650ESD	-	-
D27-750ESD	D54-750ESD	D45-750ESD	D19-750ESD	-	-

The technical design of the doors allows for the opening direction to be changed from right-handed to left-handed.

ZE 27 x 36D	ZG 54 x 36D	ZK 45 x 36D	ZL 19 x 27D	ZX 63 x 36D	ZY 72 x 36D
Order number	Order number	Order number	Order number	Order number	Order number
DP27-550ESD	DP54-550ESD	DP45-550ESD	DP19-550ESD	-	-
DP27-650ESD	DP54-650ESD	DP45-650ESD	DP19-650ESD	-	-
DP27-700ESD	DP54-700ESD	DP45-700ESD	DP19-700ESD	-	-
DP27-800ESD	DP54-800ESD	DP45-800ESD	DP19-800ESD	-	-

The technical design of the doors allows for the opening direction to be changed from right-handed to left-handed.

3 Drawers

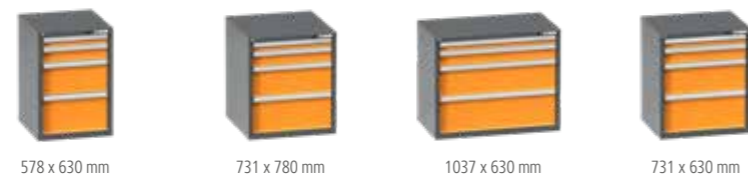

Full extension 80 kg	Front height A mm	Front height C mm	ZA 27 x 27D		ZB 36 x 36D		ZC 54 x 27D		ZD 36 x 27D	
			Order number	kg	Order number	kg	Order number	kg	Order number	kg
	75	50	ZAE75ESD	7,5	ZBE75ESD	10,1	ZCE75ESD	10,3	ZDE75ESD	8,3
	100	75	ZAE100ESD	7,9	ZBE100ESD	10,7	ZCE100ESD	11,0	ZDE100ESD	8,9
	125	75	ZAE125ESD	8,1	ZBE125ESD	11,0	ZCE125ESD	11,4	ZDE125ESD	9,2
	150	125	ZAE150ESD	8,8	ZBE150ESD	11,9	ZCE150ESD	12,4	ZDE150ESD	10,0
	200	175	ZAE200ESD	9,7	ZBE200ESD	13,1	ZCE200ESD	13,9	ZDE200ESD	11,1
	250	175	ZAE250ESD	10,1	ZBE250ESD	13,6	ZCE250ESD	14,6	ZDE250ESD	11,6
	300	275	ZAE300ESD	11,5	ZBE300ESD	15,4	ZCE300ESD	16,7	ZDE300ESD	13,2

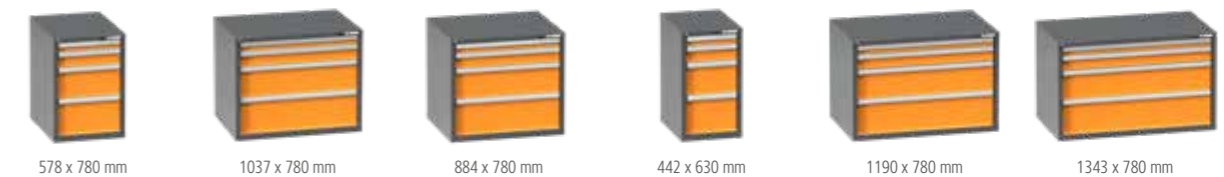
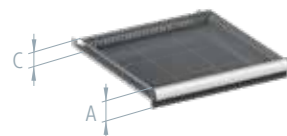

ZE 27 x 36D		ZG 54 x 36D		ZK 45 x 36D		ZL 19 x 27D		ZX 63 x 36D		ZY 72 x 36D	
Order number	kg	Order number	kg	Order number	kg	Order number	kg	Order number	kg	Order number	kg
ZEE75ESD	8,9	ZGE75ESD	12,3	ZKE75ESD	11,2	ZLE75ESD	6,5	ZXE75ESD	13,4	ZYE75ESD	14,5
ZEE100ESD	9,5	ZGE100ESD	13,1	ZKE100ESD	11,9	ZLE100ESD	6,9	ZXE100ESD	14,3	ZYE100ESD	15,5
ZEE125ESD	9,7	ZGE125ESD	13,5	ZKE125ESD	12,2	ZLE125ESD	7,1	ZXE125ESD	14,8	ZYE125ESD	16,1
ZEE150ESD	10,5	ZGE150ESD	14,7	ZKE150ESD	13,3	ZLE150ESD	7,7	ZXE150ESD	16,1	ZYE150ESD	17,5
ZEE200ESD	11,5	ZGE200ESD	16,2	ZKE200ESD	14,6	ZLE200ESD	8,4	ZXE200ESD	17,8	ZYE200ESD	19,4
ZEE250ESD	11,9	ZGE250ESD	16,9	ZKE250ESD	15,3	ZLE250ESD	8,7	ZXE250ESD	18,5	ZYE250ESD	20,1
ZEE300ESD	13,5	ZGE300ESD	19,3	ZKE300ESD	17,3	ZLE300ESD	9,9	ZXE300ESD	21,3	ZYE300ESD	23,3



Pro mobilní zásuvkové skříně je nutno objednat zásuvky opatřeny pojistkou, která brání samovolnému otevření. V případě objednávky mobilního zásuvkové skříně přidejte „P“ před ESD v objednacím kódu - např. ZAE100PESD.

4 Accessories

Mobile set



Castors diam. mm	Height castors mm	ZA 27 x 27D		ZB 36 x 36D		ZC 54 x 27D		ZD 36 x 27D	
		Order number	kg	Order number	kg	Order number	kg	Order number	kg
100	128	MK1-2727ESD	0,5/100	MK1-3636ESD	0,5/100	MK1-5427ESD	0,5/100	MK1-3627ESD	0,5/100
125	155	MK2-2727ESD	0,7/120	MK2-3636ESD	0,7/120	MK2-5427ESD	0,7/120	MK1-3627ESD	0,5/100

The set includes: 2x swivel wheels with brake, 2x fixed wheels, and a reinforcement set

Raised edge



Height mm	ZA 27 x 27D		ZB 36 x 36D		ZC 54 x 27D		ZD 36 x 27D	
	Order number	W x D mm	Order number	W x D mm	Order number	W x D mm	Order number	W x D mm
20	ZH2727ESD	578 x 630	ZH3636ESD	731 x 780	ZH5427ESD	1037 x 630	ZH3627ESD	731 x 630

1,8 kg      2,2 kg      3,2 kg      2,3 kg

The raised edge cannot be ordered separately. It includes a freely placed 3 mm rubber pad.

Handles



kg	ZA 27 x 27D		ZB 36 x 36D		ZC 54 x 27D		ZD 36 x 27D	
	Order number	Order number	Order number	Order number	Order number	Order number	Order number	
1,8	MK1	MK1	MK1	MK1	MK1	MK1	MK1	

It includes 1 pair of handles.

ZE 27 x 36D		ZG 54 x 36D		ZK 45 x 36D		ZL 19 x 27D		ZX 63 x 36D		ZY 72 x 36D	
Order number	kg	Order number	kg	Order number	kg	Order number	kg	Order number	kg	Order number	kg
MK1-2736ESD	0,5/100	MK1-5436ESD	0,5/100	MK1-4536ESD	0,5/100	MK1-1927ESD	0,5/100	-	-	-	-
MK2-2736ESD	0,7/120	MK2-5436ESD	0,7/120	MK2-4536ESD	0,7/120	MK2-1927ESD	0,7/120	-	-	-	-

The set includes: 2x swivel wheels with brake, 2x fixed wheels, and a reinforcement set

ZE 27 x 36D		ZG 54 x 36D		ZK 45 x 36D		ZL 19 x 27D		ZX 63 x 36D		ZY 72 x 36D	
Order number	W x D mm	Order number	W x D mm	Order number	W x D mm	Order number	W x D mm	Order number	W x D mm	Order number	W x D mm
ZH2736ESD	578 x 780	ZH5436ESD	1037 x 780	ZH4536ESD	884 x 780	ZH1927ESD	442 x 630	ZH6336ESD	1190 x 780	ZH7236ESD	1343 x 780

2,2 kg      3,5 kg      2,8 kg      1,8 kg      4,2 kg      4,8 kg

The raised edge cannot be ordered separately. It includes a freely placed 3 mm rubber pad.

ZE 27 x 36D		ZG 54 x 36D		ZK 45 x 36D		ZL 19 x 27D		ZX 63 x 36D		ZY 72 x 36D	
Order number	Order number	Order number	Order number	Order number	Order number	Order number	Order number	Order number	Order number	Order number	
MK1	MK1	MK1	MK1	MK1	MK1	MK1	MK1	-	-	-	

It includes 1 pair of handles.

4 Accessories

Shelf



kg
50

ZA 27 x 27D		ZB 36 x 36D		ZC 54 x 27D		ZD 36 x 27D	
Order number	W x D mm	Order number	W x D mm	Order number	W x D mm	Order number	W x D mm
VP2727ESD	564 x 515	VP3636ESD	717 x 665	VP5427ESD	1023 x 515	VP3627ESD	717 x 515
3,2 kg		4,9 kg		5,3 kg		3,9 kg	

The shelf is finished with ESD paint and is height-adjustable thanks to the perforation of the cabinet walls, 4x hook for hanging.

Plinth



Height mm
100

ZA 27 x 27D		ZB 36 x 36D		ZC 54 x 27D		ZD 36 x 27D	
Order number		Order number		Order number		Order number	
SO2727ESD		SO3636ESD		SO5427ESD		SO3627ESD	
9,5 kg		13,3 kg		17,6 kg		11,4 kg	

2 pcs of removable front panels.

Electric strip

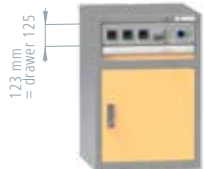

Socket type	D x H mm
E (CZ)	123 x 66
F (DE)	123 x 66

ZA 27 x 27D		ZB 36 x 36D		ZC 54 x 27D		ZD 36 x 27D	
Order number	Width mm	Order number	Width mm	Order number	Width mm	Order number	Width mm
EZS27M	504	EZS36M	657	-	-	EZS36M	657
EZS27FM	504	EZS36FM	657	-	-	EZS36FM	657
2,6 kg		3,1 kg				3,1 kg	

Equipment: 230V/16A sockets, 230V/16A circuit breaker, 1/4" pneumatic quick-connect coupling; supplied including installation into the drawer cabinet, without power cable and pneumatic hose.

Extension cord

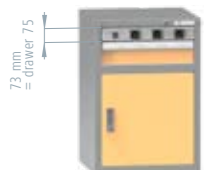

Socket type	D x H mm
E (CZ)	73 x 34
F (DE)	73 x 34

ZA 27 x 27D		ZB 36 x 36D		ZC 54 x 27D		ZD 36 x 27D	
Order number	Width mm	Order number	Width mm	Order number	Width mm	Order number	Width mm
PPZS27M	504	PPZS36M	657	-	-	PPZS36M	657
PPZS27FM	504	PPZS36FM	657	-	-	PPZS36FM	657
1,2 kg		1,4 kg				1,4 kg	

Equipment: 230V/16A sockets, 230V/16A switch; supplied including installation into the drawer cabinet, 3 m power cable with an outlet from the rear part of the profile

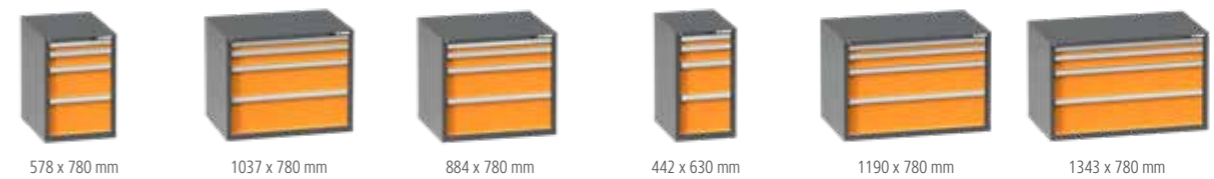

ZE 27 x 36D		ZG 54 x 36D		ZK 45 x 36D		ZL 19 x 27D		ZX 63 x 36D		ZY 72 x 36D	
Order number	W x D mm	Order number	W x D mm	Order number	W x D mm	Order number	W x D mm	Order number	W x D mm	Order number	W x D mm
VP2736ESD	564 x 665	VP5436ESD	1023 x 665	VP4536ESD	870 x 665	VP1927ESD	428 x 515	-	-	-	-
4,0 kg		6,7 kg		5,7 kg		2,5 kg					

The shelf is finished with ESD paint and is height-adjustable thanks to the perforation of the cabinet walls, 4x hook for hanging.

ZE 27 x 36D		ZG 54 x 36D		ZK 45 x 36D		ZL 19 x 27D		ZX 63 x 36D		ZY 72 x 36D	
Order number		Order number		Order number		Order number		Order number		Order number	
SO2736ESD		SO5436ESD		SO4536ESD		SO1927ESD		SO6336ESD		SO7236ESD	
11,1 kg		20,7 kg		18,6 kg		7,8 kg		22,8 kg		24,8 kg	

2 pcs of removable front panels.

ZE 27 x 36D		ZG 54 x 36D		ZK 45 x 36D		ZL 19 x 27D		ZX 63 x 36D		ZY 72 x 36D	
Order number	Width mm	Order number	Width mm	Order number	Width mm	Order number	Width mm	Order number	Width mm	Order number	Šířka mm
EZS27M	504	-	-	EZS45M	810	-	-	-	-	-	-
EZS27FM	504	-	-	EZS45FM	810	-	-	-	-	-	-
2,6 kg				3,7 kg							

Equipment: 230V/16A sockets, 230V/16A circuit breaker, 1/4" pneumatic quick-connect coupling; supplied including installation into the drawer cabinet, without power cable and pneumatic hose.

ZE 27 x 36D		ZG 54 x 36D		ZK 45 x 36D		ZL 19 x 27D		ZX 63 x 36D		ZY 72 x 36D	
Order number	Width mm	Order number	Width mm	Order number	Width mm	Order number	Width mm	Order number	Width mm	Order number	Width mm
PPZS27M	504	-	-	PPZS45M	810	-	-	-	-	-	-
PPZS27FM	504	-	-	PPZS45FM	810	-	-	-	-	-	-
1,2 kg				1,7 kg							

Equipment: 230V/16A sockets, 230V/16A switch; supplied including installation into the drawer cabinet, 3 m power cable with an outlet from the rear part of the profile



Type E sockets for the Czech Republic and other countries.



Type F sockets for Germany and other countries.



When retrofitting an electric strip or an extension cord into the cabinet body, it is necessary to provide the cabinet body with an opening for the supply line.

**Drawer partition material**



### Drawer partition material – plastic boxes (ABS, dissipative)

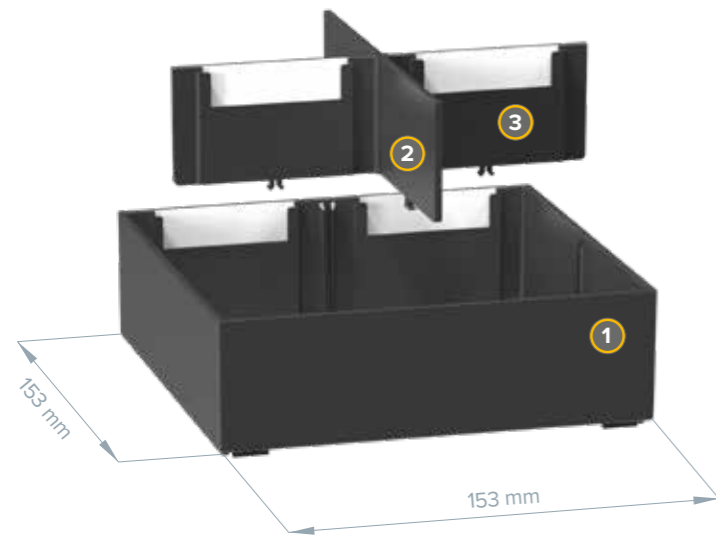

- 1 Plastic boxes the bottom design allows stacking in columns, manufactured in three heights
- 2 Large divider manufactured in three heights, can be fitted with a description label size 60 x 14 mm
- 3 Small divider allows the box to be divided into quarters



Box

Min. drawer front height mm	Order number	W x D x H mm
75	PK25ESD	153 x 153 x 25



Large divider

Order number
PK25-2ESD



Small divider

Order number
PK25-1ESD

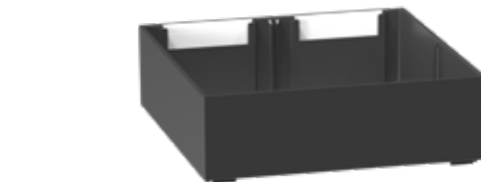

Box

Min. drawer front height mm	Order number	W x D x H mm
75	PK50ESD	153 x 153 x 47



Large divider

Order number
PK50-2ESD



Small divider

Order number
PK50-1ESD



Box

Min. drawer front height mm	Order number	W x D x H mm
100	PK75ESD	153 x 153 x 72



Large divider

Order number
PK75-2ESD



Small divider

Order number
PK75-1ESD

### Drawer partition material – plastic trays (ABS, dissipative)

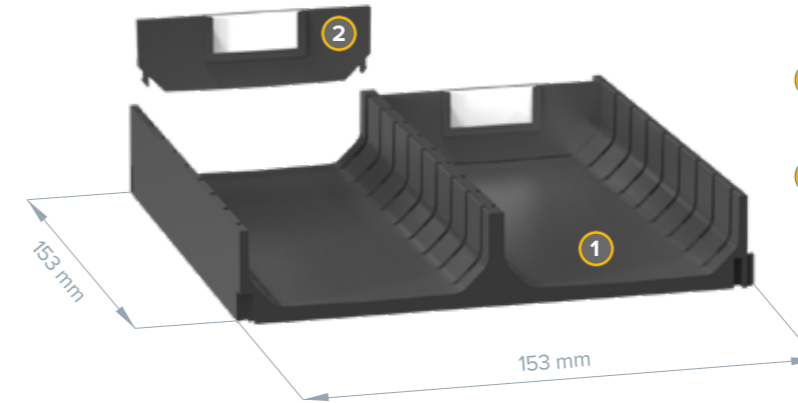

- 1 Plastic trays the design allows mutual connection, manufactured in three heights, dividing pitch in increments of 17 mm
- 2 Divider manufactured in three heights, can be fitted with a description label size 29 x 12 mm



2-part tray

Tray width mm	Order number	W x D x H mm
75	PU2ESD	153 x 153 x 28



Divider

Order number
PU2-1ESD



3-part tray

Tray width mm	Order number	W x D x H mm
75	PU3ESD	153 x 153 x 28



Divider

Order number
PU3-1ESD

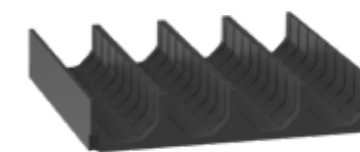

4-part tray

Tray width mm	Order number	W x D x H mm
75	PU4ESD	153 x 153 x 28



Divider

Order number
PU4-1ESD

Plastic divider sets



Boxes PK	Min. drawer front height mm	ZA 27 x 27D		ZB 36 x 36D		ZC 54 x 27D		ZD 36 x 27D	
		Order number	kg	Order number	kg	Order number	kg	Order number	kg
	75	2727PK25ESD	0,9	3636PK25ESD	1,6	5427PK25ESD	1,7	3627PK25ESD	1,1
	75	2727PK50ESD	1,4	3636PK50ESD	2,4	5427PK50ESD	2,7	3627PK50ESD	1,8
	100	2727PK75ESD	1,8	3636PK75ESD	3,2	5427PK75ESD	3,6	3627PK75ESD	2,4
		18 pcs ESD boxes, 18 pcs large dividers, 36 pcs small dividers		16 pcs ESD boxes, 16 pcs large dividers, 32 pcs small dividers		18 pcs ESD boxes, 18 pcs large dividers, 36 pcs small dividers		12 pcs ESD boxes, 12 pcs large dividers, 24 pcs small dividers	

Trays PU2	Tray width mm	ZA 27 x 27D		ZB 36 x 36D		ZC 54 x 27D		ZD 36 x 27D	
		Order number	kg	Order number	kg	Order number	kg	Order number	kg
	70	2727PU2ESD	0,8	3636PU2ESD	1,5	5427PU2ESD	1,8	3627PU2ESD	1,2
			9 pcs 2-part ESD tray, 18 pcs dividers		16 pcs 2-part ESD tray, 32 pcs dividers		18 pcs 2-part ESD tray, 36 pcs dividers		12 pcs 2-part ESD tray, 24 pcs dividers

Trays PU3	Tray width mm	ZA 27 x 27D		ZB 36 x 36D		ZC 54 x 27D		ZD 36 x 27D	
		Order number	kg	Order number	kg	Order number	kg	Order number	kg
	45	2727PU3ESD	0,9	3636PU3ESD	1,8	5427PU3ESD	2,0	3627PU3ESD	1,3
			9 pcs 3-part ESD tray, 27 pcs dividers		16 pcs 3-part ESD tray, 48 pcs dividers		18 pcs 3-part ESD tray, 54 pcs dividers		12 pcs 3-part ESD tray, 36 pcs dividers

Trays PU4	Tray width mm	ZA 27 x 27D		ZB 36 x 36D		ZC 54 x 27D		ZD 36 x 27D	
		Order number	kg	Order number	kg	Order number	kg	Order number	kg
	33	2727PU4ESD	1,2	3636PU4ESD	2,1	5427PU4ESD	2,3	3627PU4ESD	1,5
			9 pcs 4-part ESD tray, 36 pcs dividers		16 pcs 4-part ESD tray, 64 pcs dividers		18 pcs 4-part ESD tray, 72 pcs dividers		12 pcs 4-part ESD tray, 48 pcs dividers



ZE 27 x 36D		ZG 54 x 36D		ZK 45 x 36D		ZL 19 x 27D		ZX 63 x 36D		ZY 72 x 36D	
Order number	kg	Order number	kg	Order number	kg	Order number	kg	Order number	kg	Order number	kg
2736PK25ESD	1,1	5436PK25ESD	2,2	4536PK25ESD	1,9	1927PK25ESD	0,6	6336PK25ESD	2,7	7236PK25ESD	3,2
2736PK50ESD	1,8	5436PK50ESD	3,6	4536PK50ESD	3,0	1927PK50ESD	0,9	6336PK50ESD	4,2	7236PK50ESD	4,8
2736PK75ESD	2,4	5436PK75ESD	4,8	4536PK75ESD	4,0	1927PK75ESD	1,2	6336PK75ESD	5,6	7236PK75ESD	6,4
12 pcs ESD boxes, 12 pcs large dividers, 24 pcs small dividers		24 pcs ESD boxes, 24 pcs large dividers, 48 pcs small dividers		20 pcs ESD boxes, 20 pcs large dividers, 40 pcs small dividers		6 pcs ESD boxes, 6 pcs large dividers, 12 pcs small dividers		28 pcs ESD boxes, 28 pcs large dividers, 56 pcs small dividers		32 pcs ESD boxes, 32 pcs large dividers, 64 pcs small dividers	

ZE 27 x 36D		ZG 54 x 36D		ZK 45 x 36D		ZL 19 x 27D		ZX 63 x 36D		ZY 72 x 36D	
Order number	kg	Order number	kg	Order number	kg	Order number	kg	Order number	kg	Order number	kg
2736PU2ESD	1,2	5436PU2ESD	2,4	4536PU2ESD	2,0	1927PU2ESD	0,6	6336PU2ESD	2,7	7236PU2ESD	3,0
12 pcs 2-part ESD tray, 24 pcs dividers		24 pcs 2-part ESD tray, 48 pcs dividers		20 pcs 2-part ESD tray, 40 pcs dividers		6 pcs 2-part ESD tray, 12 pcs dividers		28 pcs 2-part ESD tray, 56 pcs dividers		32 pcs 2-part ESD tray, 64 pcs dividers	

ZE 27 x 36D		ZG 54 x 36D		ZK 45 x 36D		ZL 19 x 27D		ZX 63 x 36D		ZY 72 x 36D	
Order number	kg	Order number	kg	Order number	kg	Order number	kg	Order number	kg	Order number	kg
2736PU3ESD	1,3	5436PU3ESD	2,6	4536PU3ESD	2,2	1927PU3ESD	0,7	6336PU3ESD	3,1	7236PU3ESD	3,4
12 pcs 3-part ESD tray, 36 pcs dividers		24 pcs 3-part ESD tray, 72 pcs dividers		20 pcs 3-part ESD tray, 60 pcs dividers		6 pcs 3-part ESD tray, 18 pcs dividers		28 pcs 3-part ESD tray, 84 pcs dividers		32 pcs 3-part ESD tray, 96 pcs dividers	

ZE 27 x 36D		ZG 54 x 36D		ZK 45 x 36D		ZL 19 x 27D		ZX 63 x 36D		ZY 72 x 36D	
Order number	kg	Order number	kg	Order number	kg	Order number	kg	Order number	kg	Order number	kg
2736PU4ESD	1,5	5436PU4ESD	3,1	4536PU4ESD	2,6	1927PU4ESD	0,8	6336PU4ESD	3,7	7236PU4ESD	4,1
12 pcs 4-part ESD tray, 48 pcs dividers		24 pcs 4-part ESD tray, 96 pcs dividers		20 pcs 4-part ESD tray, 80 pcs dividers		6 pcs 4-part ESD tray, 24 pcs dividers		28 pcs 4-part ESD tray, 112 pcs dividers		32 pcs 4-part ESD tray, 128 pcs dividers	

## Drawer partition material – metal partition

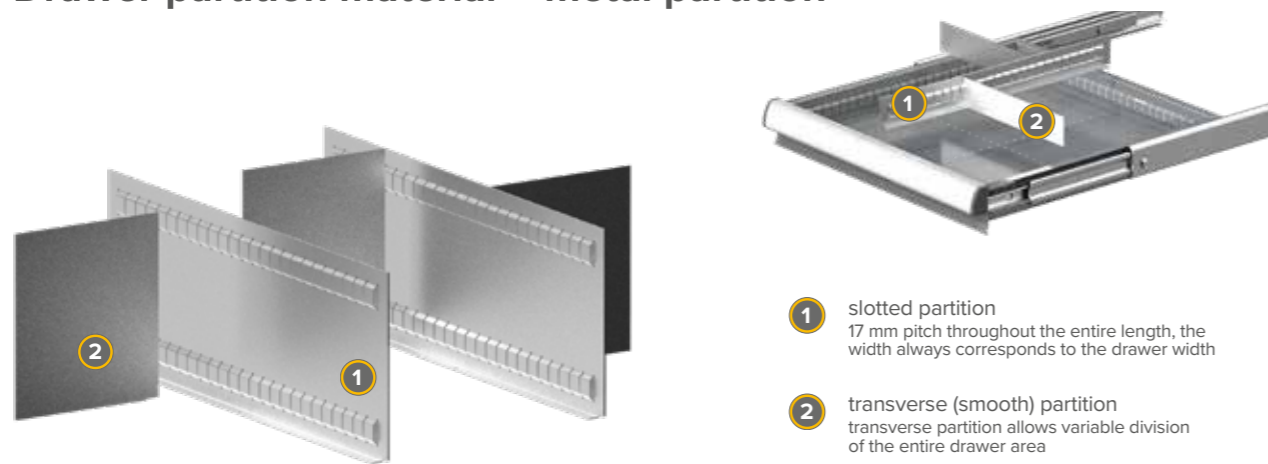

- 1** slotted partition  
17 mm pitch throughout the entire length, the width always corresponds to the drawer width
- 2** transverse (smooth) partition  
transverse partition allows variable division of the entire drawer area



Longitudinal (slotted) partitions	Front height mm	drawer width 19D	drawer width 27D	drawer width 36D	drawer width 45D	drawer width 54D
		Order number	Order number	Order number	Order number	Order number
	75	S19-75	S27-75	S36-75	S45-75	S54-75
	100, 125	S19-100	S27-100	S36-100	S45-100	S54-100
	150	S19-150	S27-150	S36-150	S45-150	S54-150
	200, 250	S19-200	S27-200	S36-200	S45-200	S54-200
	300	S19-300	S27-300	S36-300	S45-300	S54-300

Transverse (smooth) partitions	Width mm	Front height mm				
		75	100, 125	150	200, 250	300
	66 (4D)	H4-75	H4-100	H4-150	H4-200	H4-300
	83 (5D)	H5-75	H5-100	H5-150	H5-200	H5-300
	100 (6D)	H6-75	H6-100	H6-150	H6-200	H6-300
	117 (7D)	H7-75	H7-100	H7-150	H7-200	H7-300
	151 (9D)	H9-75	H9-100	H9-150	H9-200	H9-300
	185 (11D)	H11-75	H11-100	H11-150	H11-200	H11-300
	202 (12D)	H12-75	H12-100	H12-150	H12-200	H12-300
	219 (13D)	H13-75	H13-100	H13-150	H13-200	H13-300
	236 (14D)	H14-75	H14-100	H14-150	H14-200	H14-300
	253 (15D)	H15-75	H15-100	H15-150	H15-200	H15-300
	304 (18D)	H18-75	H18-100	H18-150	H18-200	H18-300
	372 (22D)	H22-75	H22-100	H22-150	H22-200	H22-300
	389 (23D)	H23-75	H23-100	H23-150	H23-200	H23-300
	457 (27D)	H27-75	H27-100	H27-150	H27-200	H27-300

## Drawer partition material – rubber mat



- 1** rubber mat  
foam rubber, 3 mm thick, serves as an anti-slip mat in the drawer



Rubber mat	kg	ZA 27 x 27D	ZB 36 x 36D	ZC 54 x 27D	ZD 36 x 27D	ZE 27 x 36D
		Order number	Order number	Order number	Order number	Order number
	0,1	PG2727ESD	PG3636ESD	PG5427ESD	PG3627ESD	PG2736ESD



Rubber mat	kg	ZG 54 x 36D	ZK 45 x 36D	ZL 19 x 27D	ZX 63 x 36D	ZY 72 x 36D
		Order number	Order number	Order number	Order number	Order number
	0,1	PG5436ESD	PG4536ESD	PG1927ESD	PG6336ESD	PG7236ESD



**Metal partition material sets**



Metal partition	Drawer front height mm	ZA 27 x 27D		ZB 36 x 36D		ZC 54 x 27D		ZD 36 x 27D	
		Order number	kg	Order number	kg	Order number	kg	Order number	kg
	75	272711	0,4	363611	0,5	542711	0,5	362711	0,4
	100, 125	272712	0,6	363612	0,8	542712	0,8	362712	0,7
	150	272713	0,9	363613	1,3	542713	1,2	362713	1,0
	200, 250	272714	1,3	363614	1,8	542714	1,6	362714	1,4
	300	272715	2,1	363615	2,8	542715	2,6	362715	2,3

2 pcs transverse partitions, 1 pc longitudinal partition

Metal partition	Drawer front height mm	ZA 27 x 27D		ZB 36 x 36D		ZC 54 x 27D		ZD 36 x 27D	
		Order number	kg	Order number	kg	Order number	kg	Order number	kg
	75	272721	0,8	363621	1,1	542721	0,9	362721	0,8
	100, 125	272722	1,3	363622	1,5	542722	1,5	362722	1,4
	150	272723	1,9	363623	2,6	542723	2,3	362723	2,0
	200, 250	272724	2,6	363624	3,6	542724	3,3	362724	2,8
	300	272725	4,2	363625	5,5	542725	5,2	362725	4,5

6 pcs transverse partitions, 2 pcs longitudinal partitions

Metal partition	Drawer front height mm	ZA 27 x 27D		ZB 36 x 36D		ZC 54 x 27D		ZD 36 x 27D	
		Order number	kg	Order number	kg	Order number	kg	Order number	kg
	75	272731	1,1	363631	1,4	542731	1,3	362731	1,2
	100, 125	272732	1,8	363632	2,1	542732	2,1	362732	1,8
	150	272733	2,5	363633	3,6	542733	3,0	362733	2,7
	200, 250	272734	3,6	363634	5,1	542734	4,3	362734	3,8
	300	272735	5,8	363635	7,6	542735	6,8	362735	6,1

8 pcs transverse partitions, 3 pcs longitudinal partitions



Metal partition	Drawer front height mm	ZE 27 x 36D		ZG 54 x 36D		ZK 45 x 36D		ZL 19 x 27D		ZX 63 x 36D		ZY 72 x 36D	
		Order number	kg	Order number	kg	Order number	kg	Order number	kg	Order number	kg	Order number	kg
	75	273611	0,5	543611	0,6	453611	0,6	192711	0,4	633611	0,2	723611	0,8
	100, 125	273612	0,7	543612	0,9	453612	0,8	192712	0,6	633612	1,0	723612	1,1
	150	273613	1,2	543613	1,5	453613	1,4	192713	0,9	633613	1,6	723613	1,7
	200, 250	273614	1,7	543614	2,0	453614	2,0	192714	1,2	633614	2,1	723614	2,2
	300	273615	2,6	543615	3,1	453615	3,0	192715	2,0	633615	3,2	723615	3,3

2 pcs transverse partitions, 1 pc longitudinal partition

Metal partition	Drawer front height mm	ZE 27 x 36D		ZG 54 x 36D		ZK 45 x 36D		ZL 19 x 27D		ZX 63 x 36D		ZY 72 x 36D	
		Order number	kg	Order number	kg	Order number	kg	Order number	kg	Order number	kg	Order number	kg
	75	273621	1,0	543621	1,2	453621	1,1	192721	0,7	633621	1,3	723621	1,4
	100, 125	273622	1,5	543622	1,7	453622	1,7	192722	1,2	633622	1,8	723622	1,9
	150	273623	2,4	543623	2,9	453623	2,8	192723	1,7	633623	3,0	723623	3,1
	200, 250	273624	3,4	543624	4,1	453624	3,9	192724	2,5	633624	4,2	723624	4,3
	300	273625	5,2	543625	6,2	453625	5,9	192725	3,9	633625	6,3	723625	6,4

6 pcs transverse partitions, 2 pcs longitudinal partitions

Metal partition	Drawer front height mm	ZE 27 x 36D		ZG 54 x 36D		ZK 45 x 36D		ZL 19 x 27D		ZX 63 x 36D		ZY 72 x 36D	
		Order number	kg	Order number	kg	Order number	kg	Order number	kg	Order number	kg	Order number	kg
	75	273631	1,4	543631	1,6	453631	1,5	192731	1,1	633631	1,2	723631	1,3
	100, 125	273632	2,1	543632	2,3	453632	2,3	192732	1,7	633632	2,4	723632	2,5
	150	273633	3,4	543633	3,9	453633	3,8	192733	2,4	633633	3,4	723633	4,1
	200, 250	273634	4,8	543634	5,5	453634	5,3	192734	3,5	633634	5,6	723634	5,2
	300	273635	7,3	543635	8,3	453635	8,0	192735	5,5	633635	8,4	723635	8,5

8 pcs transverse partitions, 3 pcs longitudinal partitions

# Workbenches





**LIGHT ESD workbenches have an adjustable working height from 665 to 1035 mm and are available in widths of 1200, 1500, 2000, and 2500 mm**, allowing easy adaptation to various types of operations. The workbench design is engineered as a lightweight version, ensuring easy manipulation while providing high stability and reliability. The antistatic worktop with a conductive core is equipped with a grounding terminal with a protective resistor for connecting a wrist strap. **Metal parts are finished with ESD**

**powder coating, and individual cabinet bodies feature grounding points.** The workbenches can also be equipped with swivel wheels with brakes (diameter 80 mm) for easy and safe relocation. Thanks to the extensions, necessary tools and materials can be organized clearly in a small area so they are always within reach. **Workbenches meet the requirements of ČSN EN 61340-5-1 (IEC 61340-5-1:2016).** Small plastic parts such as lock bodies, handles, plugs, and labels **are not ESD** conductive.



**1** Worktop  
antistatic worktop with a conductive core, equipped with a grounding terminal and protective resistor for connecting an ESD wrist strap

**2** Construction  
lightweight version ensures easy manipulation, high stability, and reliability. **Workbenches have an adjustable working height of 665 – 1035 mm**

**3** Drawer cabinet  
two variants of suspended cabinet bodies, finished with ESD paint. **The suspended cabinet body can be placed on both the right and left side of the workbench.**

**4** Accessories  
Option to equip drawers with metal or ESD plastic partition material (trays, boxes)

**i** To maintain full ESD protection, we recommend connecting the workplace to a grounding point and using ESD accessories.

### Workbench worktops

Select a suitable worktop according to your needs – **ESD laminate in thickness (D), width (C), and depth (E).**

Type	Height D mm	Width C mm	Depth E mm
ESD laminate	25	1200	700
ESD laminate	25	1500	800
ESD laminate	25	2000	
ESD laminate	25	2500	



### Workbench worktops

An antistatic worktop with a thickness of 25 mm is made of laminate material with a conductive core for optimal discharge of electrostatic charge according to the **EN 61340-5-1** standard. The surface of the worktop is highly resistant to scratching and easy to maintain. The worktop is equipped with a grounding terminal with a protective resistor for safe connection of the worker's ESD wrist strap. Mounting the legs or drawer cabinets is performed standardly using M8 x 25 screws. **This type of worktop is intended for EPA workplaces in a dry environment.**

Antistatic worktops have a surface with permanently conductive or dissipative properties, allowing **safe discharge of electrostatic charge and preventing damage to sensitive** electronic components.

**M8 x 25 screws**, which are part of the accessories, **are used to fix** the drawer cabinets to the frame

### Swivel wheels with brakes

The brake locks the wheel and simultaneously the wheel fork against rotation around its axis. For the light workbench, we offer swivel wheels with brakes in a diameter of 80 mm. **Wheels are manufactured in an antistatic version.**

### Accessories

**Drawer partition**  
Boxes in three heights,  
Trays in three widths,  
Metal partition.

**Internal shelf**  
Load capacity 50 kg, height-adjustable by 50 mm thanks to the perforation of the cabinet walls. Finished with ESD paint.

### Variants of LIGHT workbenches

Choose the appropriate variant of the workbench assembly. **We offer 5 width variants in 1200, 1500, 2000, and 2500 mm widths.** If you choose a workbench with a drawer cabinet, a detailed guide for the custom configuration of the drawer cabinet **can be found on page 31.**

Variants of LIGHT workbenches:

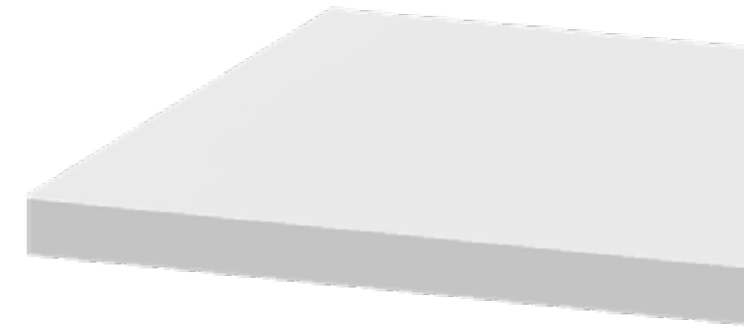

Technical specifications of the worktop according to IEC 61340-5-1  
Volume resistance  $R_d$   $1 \times 10^4 - 1 \times 10^9$  Ohm  
Measurement conditions: 20% RH, 20-30°C, 96h

### Workbench construction

The construction of **LIGHT** workbenches is engineered with an emphasis on the optimal ratio between strength and weight. **The lightweight version** ensures easy manipulation and installation while maintaining sufficient stability and reliability for everyday operation. **Quality materials and precise workshop processing contribute** to the long service life of the entire workbench.

## Standard configuration depth 700 mm



Workbench worktop depth 700 mm

Worktop	Order number	W mm	H mm	kg	kg
ESD laminate 25 mm	AR2712ESD	1200	665 - 1035	200	34
ESD laminate 25 mm	AR2715ESD	1500	665 - 1035	190	38
ESD laminate 25 mm	AR2720ESD	2000	665 - 1035	180	46
ESD laminate 25 mm	AR2725ESD	2500	665 - 1035	170	53



Workbench worktop depth 700 mm

H mm	Order number	W mm	H mm	kg	kg
	PR2712ESD	1200	665 - 1035	200	52
ESD laminate 25 mm	PR2715ESD	1500	665 - 1035	190	56
ESD laminate 25 mm	PR2720ESD	2000	665 - 1035	180	64
ESD laminate 25 mm	PR2725ESD	2500	665 - 1035	170	71

Light workbench equipped with suspended drawer cabinet ZA19-1.  
Drawers: 1x 100 ZAE



Workbench worktop depth 700 mm

Worktop	Order number	W mm	H mm	kg	kg
ESD laminate 25 mm	BR2712ESD	1200	665 - 1035	200	68
ESD laminate 25 mm	BR2715ESD	1500	665 - 1035	190	72
ESD laminate 25 mm	BR2720ESD	2000	665 - 1035	180	80
ESD laminate 25 mm	BR2725ESD	2500	665 - 1035	170	87

Light workbench equipped with suspended drawer cabinet ZA39-2.  
Drawers: 1x 100 ZAE, 1x 200 ZAE



Workbench worktop depth 700 mm

Worktop	Order number	W mm	H mm	kg	kg
ESD laminate 25 mm	HR2712ESD	1200	665 - 1035	200	99
ESD laminate 25 mm	HR2715ESD	1500	665 - 1035	190	103
ESD laminate 25 mm	HR2720ESD	2000	665 - 1035	180	111
ESD laminate 25 mm	HR2725ESD	2500	665 - 1035	170	118

Light workbench equipped with drawer cabinet ZAK74.  
Drawers: 2x ZAE 100, 2x ZAE 125, 1x ZAE 200



Workbench worktop depth 700 mm

Worktop	Order number	W mm	H mm	kg	kg
ESD laminate 25 mm	-	1200	-	-	-
ESD laminate 25 mm	OR2715ESD	1500	815	190	168
ESD laminate 25 mm	OR2720ESD	2000	815	180	176
ESD laminate 25 mm	OR2725ESD	2500	815	170	183

Light workbench equipped with 2 drawer cabinets ZAK74.  
Drawers: 4x ZAE 100, 4x ZAE 125, 2x ZAE 200

## Standard configuration depth 800 mm



Workbench worktop depth 800 mm

Worktop	Order number	W mm	H mm	kg	kg
ESD laminate 25 mm	AR2812ESD	1200	665 - 1035	200	36,1
ESD laminate 25 mm	AR2815ESD	1500	665 - 1035	190	41
ESD laminate 25 mm	AR2820ESD	2000	665 - 1035	180	50
ESD laminate 25 mm	AR2825ESD	2500	665 - 1035	170	58



Workbench worktop depth 800 mm

Worktop	Order number	W mm	H mm	kg	kg
ESD laminate 25 mm	PR2812ESD	1200	665 - 1035	200	54,1
ESD laminate 25 mm	PR2815ESD	1500	665 - 1035	190	59
ESD laminate 25 mm	PR2820ESD	2000	665 - 1035	180	68
ESD laminate 25 mm	PR2825ESD	2500	665 - 1035	170	76

Light workbench equipped with suspended drawer cabinet ZA19-1.  
Drawers: 1x 100 ZAE



Workbench worktop depth 800 mm

Worktop	Order number	W mm	H mm	kg	kg
ESD laminate 25 mm	BR2812ESD	1200	665 - 1035	200	70,1
ESD laminate 25 mm	BR2815ESD	1500	665 - 1035	190	75
ESD laminate 25 mm	BR2820ESD	2000	665 - 1035	180	84
ESD laminate 25 mm	BR2825ESD	2500	665 - 1035	170	92

Light workbench equipped with suspended drawer cabinet ZA39-2.  
Drawers: 1x 100 ZAE, 1x 200 ZAE



Workbench worktop depth 800 mm

Worktop	Order number	W mm	H mm	kg	kg
ESD laminate 25 mm	HR2812ESD	1200	665 - 1035	200	101,1
ESD laminate 25 mm	HR2815ESD	1500	665 - 1035	190	106
ESD laminate 25 mm	HR2820ESD	2000	665 - 1035	180	115
ESD laminate 25 mm	HR2825ESD	2500	665 - 1035	170	123

Light workbench equipped with drawer cabinet ZAK74.  
Drawers: 2x ZAE 100, 2x ZAE 125, 1x ZAE 200



Workbench worktop depth 800 mm

Worktop	Order number	W mm	H mm	kg	kg
ESD laminate 25 mm	-	1200	-	-	-
ESD laminate 25 mm	OR2815ESD	1500	815	190	171
ESD laminate 25 mm	OR2820ESD	2000	815	180	180
ESD laminate 25 mm	OR2825ESD	2500	815	170	188

Light workbench equipped with 2 drawer cabinets ZAK74.  
Drawers: 4x ZAE 100, 4x ZAE 125, 2x ZAE 200

## Custom configuration

### How to set up a custom configuration of a workbench

- Choose the type and accessories of the worktop.
- Choose the wheels for the workbench.
- Choose the size of the cabinet body.
- Choose the number of drawers so that the sum of front heights **A** (or doors) equals the clear opening of the cabinet body **S**.
- Choose doors or doors with a threshold.
- Choose the color of the cabinet body and drawers.
- Choose accessories.
- Choose drawer partition material.



### 1 Workbench assembly / worktop

Choose a suitable variant of the workbench assembly. We offer 5 variants of stationary workbenches in widths of 1200, 1500, 2000, and 2500 mm and 3 variants of mobile workbenches in widths of 1200, 1500, and 2000 mm. If you choose a workbench with a drawer cabinet, a detailed guide for the custom configuration of the drawer cabinet can be found on page 31.

Workstation setups:



**i** Suspended drawer cabinets can be placed on both the right and left side of the workbench.

Select a suitable worktop according to your needs – ESD laminate in thickness (D), width (C), and depth (E).

Type	Height D mm	Width C mm	Depth E mm
ESD laminate	25	1200	700
ESD laminate	25	1500	800
ESD laminate	25	2000	
ESD laminate	25	2500	



### 2 Wheels

Wheels represent a configuration element that enables workplace mobility while maintaining stability. For LIGHT workbenches, we offer swivel wheels with brakes in a diameter of 80 mm. The braking mechanism locks not only the wheel itself but also its swivel fork against rotation around its axis.



For mobile workbenches, it is necessary to order drawers equipped with a safety catch, which prevents spontaneous opening. In the case of ordering a mobile workbench, add the letter „P“ after the order code of the drawer.

Wheels are supplied in an antistatic version to maintain the ESD parameters of the workplace.

### 3 Cabinet body

Select the appropriate cabinet body size according to your needs. There are 2 footprints and 5 heights available.

Dimension H = total height of the cabinet body  
Dimension S = clear opening of the cabinet body

Body cabinet footprints:

Type	W x D mm
ZA 27 x 27D	578 x 630
ZB 36 x 36D	731 x 780

Cabinet body height:

Dimension S mm	100	300	650	750	900
Dimension H mm	190	390	740	840	990

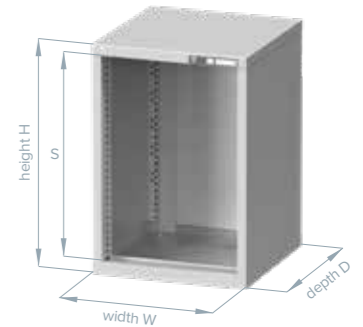

### 4 Doors / doors with a threshold

Doors are suitable only for PPS workbenches. If you choose a cabinet only with doors, the clear opening dimension of the cabinet body **S** must equal the door height. In case of a combination of drawers and doors, the clear opening dimension of the cabinet body **S** must equal the height of the doors with a threshold plus the sum of heights **A** of the selected drawers.

**Example assembly**  
Cabinet body: ZAK84ESD (S = 750 mm)  
Drawers: ZAE75ESD (A = 75 mm), ZAE125ESD (A = 125 mm)  
Doors with threshold: DP27-550ESD (550 mm)



### 5 Drawers

Choose the composition of drawers / doors for the drawer cabinet. The clear opening of the cabinet body **S** must equal the sum of heights **A** of the selected drawers or doors. The drawer size marked as **C** determines the side wall height, which is important for choosing metal partition material for the drawer.

Drawer height:

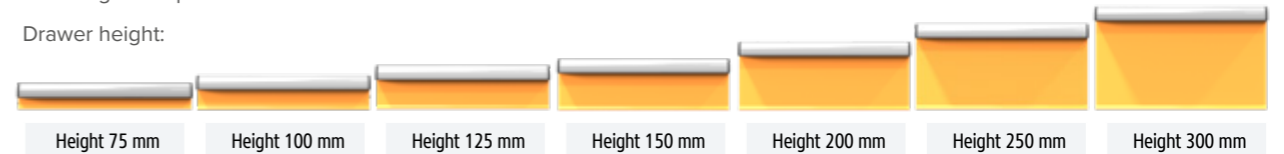

### 6 Accessories



**Drawer partition**  
Boxes in three heights,  
Trays in three widths,  
Metal partition.



**Internal shelf**  
Load capacity 50 kg, thanks to the perforation of the walls, it is height-adjustable by 50 mm. Finished with ESD paint.

**1 Workbench assembly**

**STATIONARY workbench design**



Worktop type	Thickness mm	Width mm	depth 700 mm		depth 700 mm		depth 700 mm	
			Order number	kg	Order number	kg	Order number	kg
ESD lamino	25 mm	1200	AR2712ESD	34/200	AR2712ESD	34/200	AR2712ESD	34/200
		1500	AR2715ESD	38/190	AR2715ESD	38/190	AR2715ESD	38/190
		2000	AR2720ESD	46/180	AR2720ESD	46/180	AR2720ESD	46/180
		2500	AR2725ESD	53/170	AR2725ESD	53/170	AR2725ESD	53/170

Workbench construction with ESD laminate worktop.

**MOBILE workbench design**



Worktop type	Thickness mm	Width mm	Order number		Order number		Order number	
			kg	kg	kg	kg	kg	kg
ESD lamino	25 mm	1200	MAR2712ESD	35,6/200	MAR2712ESD	35,6/200	-	-
		1500	MAR2715ESD	39,6/190	MAR2715ESD	39,6/190	-	-
		2000	MAR2720ESD	47,6/180	MAR2720ESD	47,6/180	-	-
		2500	MAR2725ESD	54,6/170	MAR2725ESD	54,6/170	-	-

Workbench construction with ESD laminate worktop + 4 swivel ESD wheels with brakes.

**2 Cabinet body**

**Drawer cabinet body**

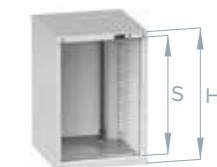

W x D mm	depth 700 mm			depth 700 mm			depth 700 mm		
	Order number	S mm	H mm	Order number	S mm	H mm	Order number	S mm	H mm
ZA 27 x 27D 578 x 630	-	-	-	ZAK19LESD	100	190	ZAK69ESD	600	690
	-	-	-	ZAK39LESD	300	390	ZAK74ESD	650	740
	-	-	-	-	-	-	ZAK84ESD	750	840
	-	-	-	-	-	-	-	-	-

150 kg      250 kg      700 kg

**3 Doors**

**Doors**



Height S mm	depth 700 mm		depth 700 mm		depth 700 mm	
	Order number	Order number	Order number	Order number	Order number	Order number
600	-	-	-	-	D27-600ESD	D27-600ESD
650	-	-	-	-	D27-650ESD	D27-650ESD
750	-	-	-	-	D27-750ESD	D27-750ESD

The technical construction of the doors allows for the opening direction to be changed from right-handed to left-handed.



depth 700 mm		depth 800 mm		depth 800 mm		depth 800 mm		depth 800 mm	
Order number	kg	Order number	kg	Order number	kg	Order number	kg	Order number	kg
AR2712ESD	34/200	AR2812ESD	36,1/200	AR2812ESD	36,1/200	AR2812ESD	36,1/200	AR2812ESD	36,1/200
AR2715ESD	38/190	AR2815ESD	41/190	AR2815ESD	41/190	AR2815ESD	41/190	AR2815ESD	41/190
AR2720ESD	46/180	AR2820ESD	50/180	AR2820ESD	50/180	AR2820ESD	50/180	AR2820ESD	50/180
AR2725ESD	53/170	AR2825ESD	58/170	AR2825ESD	58/170	AR2825ESD	58/170	AR2825ESD	58/170

Workbench design with ESD laminate worktop.

Order number	kg	Order number	kg	Order number	kg	Order number	kg	Order number	kg
-	-	MAR2812ESD	37,7/200	MAR2812ESD	37,7/200	-	-	-	-
-	-	MAR2815ESD	42,6/190	MAR2815ESD	42,6/190	-	-	-	-
-	-	MAR2820ESD	51,6/180	MAR2820ESD	51,6/180	-	-	-	-
-	-	MAR2825ESD	59,6/170	MAR2825ESD	59,6/170	-	-	-	-

Workbench construction with ESD laminate worktop + 4 swivel ESD wheels with brakes.

depth 700 mm			depth 800 mm			depth 800 mm			depth 800 mm			depth 800 mm		
Order number	S mm	H mm	Order number	S mm	H mm	Order number	S mm	H mm	Order number	S mm	H mm	Order number	S mm	H mm
ZAK69ESD	600	690	-	-	-	ZAK19LESD	100	190	ZAK69ESD	600	690	ZAK69ESD	600	690
ZAK74ESD	650	740	-	-	-	ZAK39LESD	300	390	ZAK74ESD	650	740	ZAK74ESD	650	740
ZAK84ESD	750	840	-	-	-	-	-	-	ZAK84ESD	750	840	ZAK84ESD	750	840

700 kg      150 kg      250 kg      700 kg      700 kg

depth 700 mm		depth 800 mm		depth 800 mm		depth 800 mm		depth 800 mm	
Order number	Order number	Order number	Order number	Order number	Order number	Order number	Order number	Order number	Order number
D27-600ESD	-	-	-	D27-600ESD	D27-600ESD	D27-600ESD	D27-600ESD	D27-600ESD	D27-600ESD
D27-650ESD	-	-	-	D27-650ESD	D27-650ESD	D27-650ESD	D27-650ESD	D27-650ESD	D27-650ESD
D27-750ESD	-	-	-	D27-750ESD	D27-750ESD	D27-750ESD	D27-750ESD	D27-750ESD	D27-750ESD

The technical construction of the doors allows for the opening direction to be changed from right-handed to left-handed.



**3 Doors with threshold**



Doors with threshold	Height mm
	500 + 50 threshold
	600 + 50 threshold



depth 700 mm		depth 700 mm		depth 700 mm	
Order number	kg	Order number	kg	Order number	kg
-	-	-	-	DP27-550ESD	7,5
-	-	-	-	DP27-650ESD	11,5

The technical construction of the doors allows for the opening direction to be changed from right-handed to left-handed.

**4 Drawers**

depth 700 mm		depth 700 mm		depth 700 mm	
Order number	kg	Order number	kg	Order number	kg
-	-	ZAE75ESD	7,5	ZAE75ESD	7,5
-	-	ZAE100ESD	7,9	ZAE100ESD	7,9
-	-	ZAE125ESD	8,1	ZAE125ESD	8,1
-	-	ZAE150ESD	8,8	ZAE150ESD	8,8
-	-	ZAE200ESD	9,7	ZAE200ESD	9,7
-	-	ZAE250ESD	10,1	ZAE250ESD	10,1
-	-	ZAE300ESD	11,5	ZAE300ESD	11,5

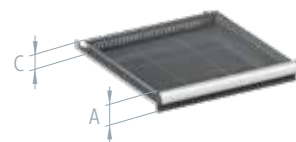

Full extension  
80 kg

Front height A mm	Front height C mm
75	50
100	75
125	75
150	125
200	175
250	175
300	275



depth 700 mm		depth 800 mm		depth 800 mm		depth 800 mm		depth 800 mm	
Order number	kg	Order number	kg	Order number	kg	Order number	kg	Order number	kg
DP27-550ESD	7,5	-	-	-	-	DP27-550ESD	7,5	DP27-550ESD	7,5
DP27-650ESD	11,5	-	-	-	-	DP27-650ESD	11,5	DP27-650ESD	11,5

The technical construction of the doors allows for the opening direction to be changed from right-handed to left-handed.

depth 700 mm		depth 700 mm		depth 700 mm		depth 700 mm		depth 700 mm	
Order number	kg	Order number	kg	Order number	kg	Order number	kg	Order number	kg
ZAE75ESD	7,5	-	-	ZAE75ESD	7,5	ZAE75ESD	7,5	ZAE75ESD	7,5
ZAE100ESD	7,9	-	-	ZAE100ESD	7,9	ZAE100ESD	7,9	ZAE100ESD	7,9
ZAE125ESD	8,1	-	-	ZAE125ESD	8,1	ZAE125ESD	8,1	ZAE125ESD	8,1
ZAE150ESD	8,8	-	-	ZAE150ESD	8,8	ZAE150ESD	8,8	ZAE150ESD	8,8
ZAE200ESD	9,7	-	-	ZAE200ESD	9,7	ZAE200ESD	9,7	ZAE200ESD	9,7
ZAE250ESD	10,1	-	-	ZAE250ESD	10,1	ZAE250ESD	10,1	ZAE250ESD	10,1
ZAE300ESD	11,5	-	-	ZAE300ESD	11,5	ZAE300ESD	11,5	ZAE300ESD	11,5



For mobile workbenches, it is necessary to order drawers equipped with a safety catch, which prevents spontaneous opening. **In the case of ordering a mobile workbench, add „P“ before ESD in the order code – e.g., ZAE100PESD.**

**5 Accessories**

Shelf	W x D mm	Order number	kg	Order number	kg	Order number	kg
	564 x 515	-	-	-	-	VP2727ESD	3,2/50



The shelf is finished with ESD paint and is height-adjustable thanks to the perforation of the cabinet walls; includes 4x hook for hanging

Order number	kg	Order number	kg	Order number	kg	Order number	kg	Order number	kg
VP2727ESD	3,2/50	-	-	-	-	VP2727ESD	3,2/50	VP2727ESD	3,2/50

## Workbench extensions





Extensions expand the usability of workbenches; by using them, the customer gains the ability to utilize a full range of the hanging system, including adjustable accessories from the ergonomic program. **All components are part of a special ESD program, which ensures protection against electrostatic discharge. The operator can thus better adapt and organize their workspace,**

**which, among other things, leads to reduced fatigue and a related increase in productivity.** This type of extension can be used to equip all types and widths of workbenches. **We offer extensions in four widths – 1200, 1500, 2000, and 2500 mm.** They are supplied as a complete unit in three heights – 382, 762, and 1142 mm above the worktop.



**1** Extension construction  
ESD construction supplied as a unit in four widths: 1200, 1500, 2000, and 2500 mm

**2** Extension arm  
ESD arm with an aluminum 40 x 40 mm profile, adjustable by 130 mm; can be equipped with a pneumatic quick-connect coupling

**3** Perforated / solid panels  
ESD panels in two widths: 1000 and 1500 mm and two heights: 380 and 190 mm

**4** Arm system  
movable arms with a load capacity of 10 and 30 kg for perforated panels, shelves, or holders for monitors and PCs. Finished with ESD paint

**5** Hanging system  
a wide range of ESD variants available, from shelves to various tool holders of different shapes

**6** Electrical accessories  
the extension can be equipped with lighting, an electric strip, or an extension cord

## Workbench extension variants

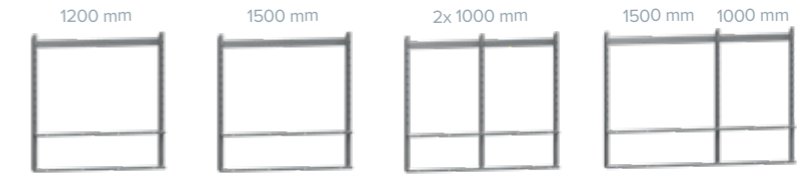

## Extension construction

The basic building elements of the extension are the uprights, which, thanks to their grooved profile, allow for the placement of panels, the arm system, and extension arms. The construction is supplied as a unit in four widths – 1200, 1500, 2000, and 2500 mm and in three heights – 382, 762, and 1142 mm.

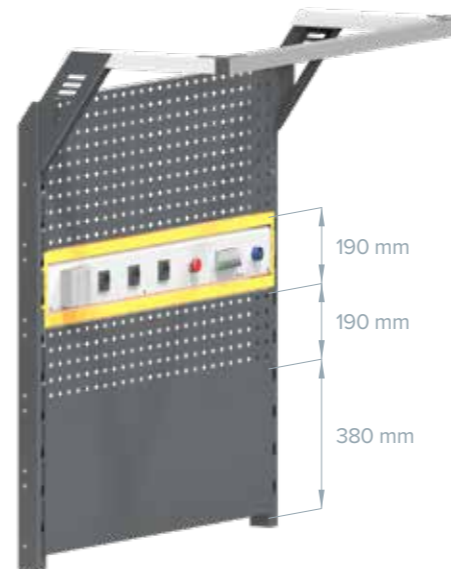

## Extension panels

### Perforated / solid panels

**Panels for the extension** are designed to fill the space between the uprights and allow for maximum utilization of the extension space. A wide range of holders and hooks can be hung on the **perforated panels** with a 38 x 38 mm pitch; **solid panels** can serve for attachment using magnets.

### Electric strip frame

The electric strip frame is suitable as a gap filler around the electric strip to **prevent objects from falling between the workbench top and the extension.**

## Extension arm

The profile is made of aluminum, **which makes it stand out for its lightness and, above all, strength.** The profile dimension is 40 x 40 mm, with grooves for T8 nuts. **The arm can be equipped with a built-in pneumatic quick-connect coupling, which you can mount on either side.** The arm is adjustable by 130 mm.



The hanging system for the extension can be found on page 81.

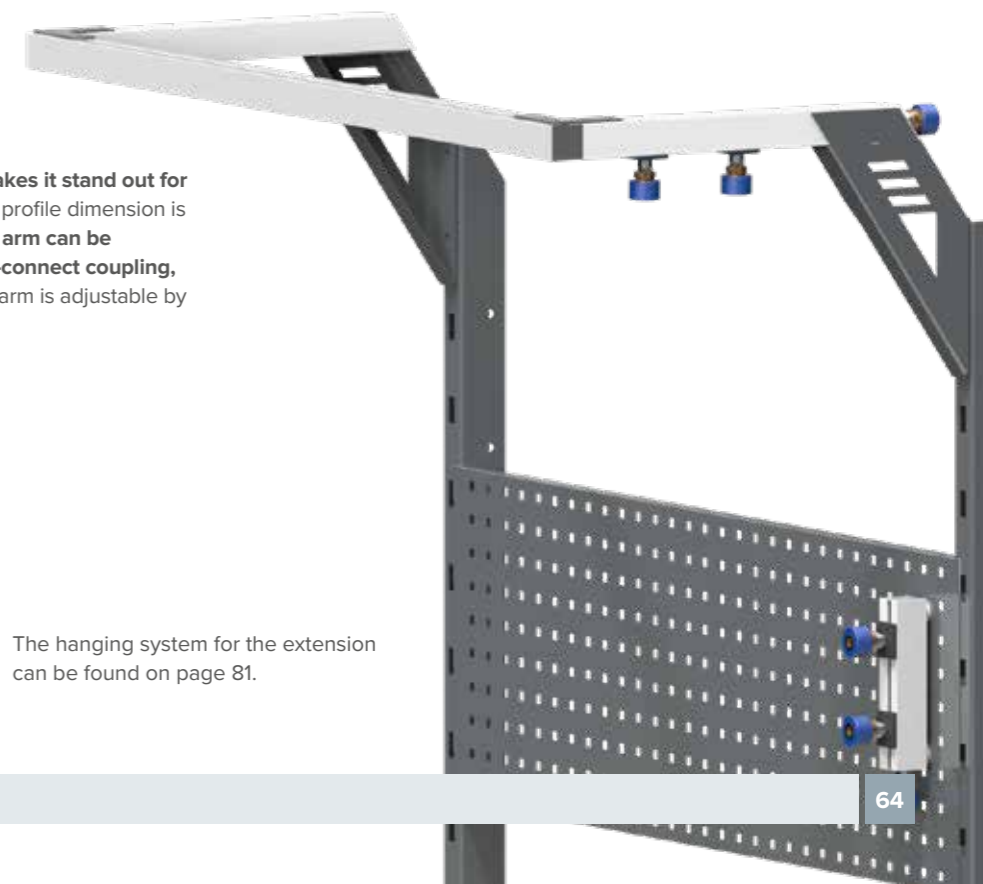

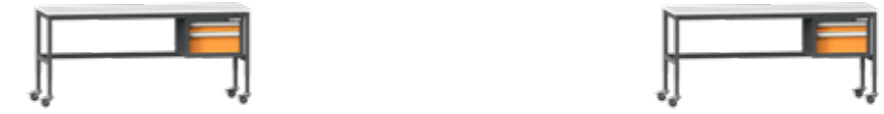

1 Extension construction

Construction for light workbenches



Height mm	Width mm	STATIONARY WORKBENCH depth 700 mm		STATIONARY WORKBENCH depth 800 mm	
		Order number	Person / Weight kg	Order number	Person / Weight kg
1142	1200	NS14L-3ESD	11,5/60	NS14L-3ESD	11,5/60
	1500	NS15L-3ESD	12,5/60	NS15L-3ESD	12,5/60
	2000	NS16L-3ESD	13/60	NS16L-3ESD	13/60
	2500	NS17L-3ESD	19/60	NS17L-3ESD	19/60
762	1200	NS14L-2ESD	10,5/60	NS14L-2ESD	10,5/60
	1500	NS15L-2ESD	11,5/60	NS15L-2ESD	11,5/60
	2000	NS16L-2ESD	17/60	NS16L-2ESD	17/60
	2500	NS17L-2ESD	18/60	NS17L-2ESD	18/60
382	1200	NS14L-1ESD	7,5/30	NS14L-1ESD	7,5/30
	1500	NS15L-1ESD	8,5/30	NS15L-1ESD	8,5/30
	2000	NS16L-1ESD	14/30	NS16L-1ESD	14/30
	2500	NS17L-1ESD	15/30	NS17L-1ESD	15/30

MOBILE WORKBENCH depth 700 mm		MOBILE WORKBENCH depth 800 mm	
Order number	Person / Weight kg	Order number	Person / Weight kg
NS15L-3ESD	11,5/60	NS15L-3ESD	11,5/60
NS15L-3ESD	12,5/60	NS15L-3ESD	12,5/60
NS16L-3ESD	13/60	NS16L-3ESD	13/60
NS17L-3ESD	19/60	NS17L-3ESD	19/60
NS14L-2ESD	10,5/60	NS14L-2ESD	10,5/60
NS15L-2ESD	11,5/60	NS15L-2ESD	11,5/60
NS16L-2ESD	17/60	NS16L-2ESD	17/60
NS17L-2ESD	18/60	NS17L-2ESD	18/60
NS14L-1ESD	7,5/30	NS14L-1ESD	7,5/30
NS15L-1ESD	8,5/30	NS15L-1ESD	8,5/30
NS16L-1ESD	14/30	NS16L-1ESD	14/30
NS17L-1ESD	15/30	NS17L-1ESD	15/30



The arm profile is made of aluminum, which makes it stand out for its lightness and, above all, strength. The arm is adjustable by 130 mm. The hanging system range for the workbench extension can be found on page 81.



When choosing an extension of a specific width, it is necessary to select an arm of the corresponding size. Combining elements with different widths is not possible for construction reasons.

Extension arm with aluminum profil



Width mm	STATIONARY WORKBENCH depth 700 mm		STATIONARY WORKBENCH depth 800 mm	
	Order number	Person / Weight kg	Order number	Person / Weight kg
1200	8ALNR12ESD	5,7/6	8ALNR12ESD	5,7/6
1500	8ALNR15ESD	6,2/6	8ALNR15ESD	6,2/6
2000	8ALNR20ESD	7,2/6	8ALNR20ESD	7,2/6
2500	8ALNR25ESD	8,1/6	8ALNR25ESD	8,1/6

Extension arm with pneumatic quick-connect coupling



Width mm	STATIONARY WORKBENCH depth 700 mm		STATIONARY WORKBENCH depth 800 mm	
	Order number	Person / Weight kg	Order number	Person / Weight kg
1200	8ALNRPN12ESD	6,8/6	8ALNRPN12ESD	6,8/6
1500	8ALNRPN15ESD	7,4/6	8ALNRPN15ESD	7,4/6
2000	8ALNRPN20ESD	8,3/6	8ALNRPN20ESD	8,3/6
2500	8ALNRPN25ESD	9,2/6	8ALNRPN25ESD	9,2/6

Arms are supplied without the extension construction. Dimensions of the aluminum profile are 40 x 40 mm with grooves for T8 nuts. The pneumatic quick-connect coupling can be mounted on both sides of the arm or ordered separately.

MOBILE WORKBENCH depth 700 mm

Order number	Person / Weight kg	MOBILE WORKBENCH depth 800 mm	Person / Weight kg
8ALNR12ESD	5,7/6	8ALNR12ESD	5,7/6
8ALNR15ESD	6,2/6	8ALNR15ESD	6,2/6
8ALNR20ESD	7,2/6	8ALNR20ESD	7,2/6
8ALNR25ESD	8,1/6	8ALNR25ESD	8,1/6

MOBILE WORKBENCH depth 700 mm

Order number	Person / Weight kg	MOBILE WORKBENCH depth 800 mm	Person / Weight kg
8ALNRPN12ESD	6,8/6	8ALNRPN12ESD	6,8/6
8ALNRPN15ESD	7,4/6	8ALNRPN15ESD	7,4/6
8ALNRPN20ESD	8,3/6	8ALNRPN20ESD	8,3/6
8ALNRPN25ESD	9,2/6	8ALNRPN25ESD	9,2/6

Arms are supplied without the extension construction. Dimensions of the aluminum profile are 40 x 40 mm with grooves for T8 nut . The pneumatic quick-connect coupling can be mounted on both sides of the arm or ordered separately.

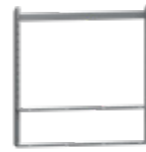
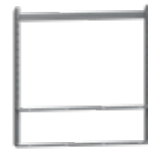

**2 Extension equipment**

Perforated panel	Height mm	Width mm	width 1200 mm		width 1500 mm	
			Order number	kg	Order number	kg
	380	1000	-	-	-	-
	380	1200	8NPP12ESD (max 3)	3,7	-	-
	380	1500	-	-	8NPP15ESD (max 3)	4,7
	190	1000	-	-	-	-
	190	1200	8NPP12H (max 6)	2,1	-	-
	190	1500	-	-	8NPP15HESD (max 6)	2,6

Solid panel	Height mm	Width mm	width 1200 mm		width 1500 mm	
			Order number	kg	Order number	kg
	380	1000	-	-	-	-
	380	1200	8NP12ESD (max 3)	3,7	-	-
	380	1500	-	-	8NP15ESD	4,7

Electric strip frame	Height mm	Width mm	width 1200 mm		width 1500 mm	
			Order number	kg	Order number	kg
	190	1000	-	-	-	-
	190	1200	8NPR12ESD	1,5	-	-
	190	1500	-	-	8NPR15ESD	1,9

The electric strip frame is suitable as a gap filler around the electric strip to prevent objects from falling between the worktop and the extension.

Shelf	Depth mm	Width mm	width 1200 mm		width 1500 mm	
			Order number	kg	Order number	kg
	206	1000	-	-	-	-
	206	1200	8NPO12-1ESD	3,8	-	-
	206	1500	-	-	8NPO15-1ESD	4,5
	370	1000	-	-	-	-
	370	1200	8NPO12-2ESD	2,1	-	-
	370	1500	-	-	8NPO15-2ESD	7,0

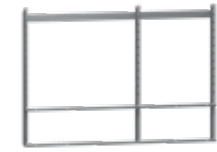
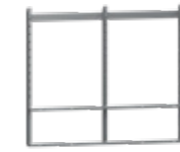

width 2000 mm		width 2500 mm	
Order number	kg	Order number	kg
8NPP10ESD (max 6)	3	8NPP10ESD (max 3)	3
-	-	-	-
-	-	8NPP15ESD (max 3)	4,7
8NPP10HESD (max 12)	1,7	8NPP10HESD (max 6)	1,7
-	-	-	-
-	-	8NPP15HESD (max 6)	2,6

Order number	kg	Order number	kg
8NP10ESD (max 6)	3,0	8NP10ESD (max 3)	3,0
-	-	-	-
-	-	8NP15ESD (max 3)	4,7

Order number	kg	Order number	kg
8NPR10ESD	1,0	8NPR10ESD	1,0
-	-	-	-
-	-	8NPR15ESD	1,9

The electric strip frame is suitable as a gap filler around the electric strip to prevent objects from falling between the work top and the extension.

Order number	kg	Order number	kg
8NPO10-1ESD	3,2	8NPO10-1ESD	3,2
-	-	-	-
-	-	8NPO15-1ESD	4,5
8NPO10-2ESD	5,0	8NPO10-2ESD	5,0
-	-	-	-
-	-	8NPO15-2ESD	7,0



### 3 Electrical accessories

#### Electric strip EN V1



Socket type	Width mm	width 1200 mm				width 1500 mm			
		Order no. without pneum. quick coup.	Order no. with pneum. quick coup.	D x H mm	kg	Order no. without pneum. quick coup.	Order no. with pneum. quick coup.	D x H mm	kg
E (CZ)	934	-	-	-	-	-	-	-	-
E (CZ)	1414	-	-	-	-	EN13	EN13P	123 x 66	5,6
F (DE)	934	-	-	-	-	-	-	-	-
F (DE)	1414	-	-	-	-	-	-	-	-

Equipment: 5x 230 V/16 A socket, 3x 230 V/16 A circuit breaker, 1/4" pneumatic quick-connect coupling; supplied without power cable (400 V / max 20 A) and pneumatic hose. Supplied **WITHOUT** the bracket for mounting between extension uprights. **Only for stationary workbenches.**

#### Electric strip EN V2



Socket type	Width mm	width 1200 mm				width 1500 mm			
		Order no. without pneum. quick coup.	Order no. with pneum. quick coup.	D x H mm	kg	Order no. without pneum. quick coup.	Order no. with pneum. quick coup.	D x H mm	kg
E (CZ)	934	-	-	-	-	-	-	-	-
E (CZ)	1414	-	-	-	-	EN23	EN23P	123 x 66	6,2
F (DE)	934	-	-	-	-	-	-	-	-
F (DE)	1414	-	-	-	-	EN23F	EN23FP	123 x 66	6,2

Equipment: 3x 230 V/16 A socket, 1x 230 V/16 A circuit breaker, 1/4" pneumatic quick-connect coupling, 1x 400 V/16 A socket, 1x 400 V/16 A circuit breaker; supplied without power cable (400 V / max 20 A) and pneumatic hose. Supplied **WITHOUT** the bracket for mounting between extension uprights. **Only for stationary workbenches.**

#### Electric strip EN V3



Socket type	Width mm	width 1200 mm				width 1500 mm			
		Order no. without pneum. quick coup.	Order no. with pneum. quick coup.	D x H mm	kg	Order no. without pneum. quick coup.	Order no. with pneum. quick coup.	D x H mm	kg
E (CZ)	934	-	-	-	-	-	-	-	-
E (CZ)	1414	-	-	-	-	EN33	EN63P	123 x 66	6,5
F (DE)	934	-	-	-	-	-	-	-	-
F (DE)	1414	-	-	-	-	EN33F	EN33FP	123 x 66	6,5

Equipment: 3x 230 V/16 A socket, 3x 230 V/16 A circuit breaker, 1/4" pneumatic quick-connect coupling, 230 V stop button, 1x 400 V/16 A socket, 1x 400 V/16 A circuit breaker, 1x 230 V/6 A circuit breaker, 230 V shunt trip; supplied without power cable (400 V / max 20 A) and pneumatic hose. Supplied **WITHOUT** the bracket for mounting between extension uprights. **Only for stationary workbenches.**



Type E sockets for the Czech Republic and other countries



Type F sockets for Germany and other countries

#### Hanging trolley



W x D x H mm	Order number	kg	Order number	kg
35 x 60 x 20	8NV1	5	8NV1	5



width 2000 mm				width 2500 mm			
Order no. without pneum. quick coup.	Order no. with pneum. quick coup.	D x H mm	kg	Order no. without pneum. quick coup.	Order no. with pneum. quick coup.	D x H mm	kg
EN11	EN11P	123 x 66	4,1	EN11	EN11P	123 x 66	4,1
-	-	-	-	EN13	EN13P	123 x 66	5,6
EN11F	EN11FP	123 x 66	4,1	EN11F	EN11FP	123 x 66	4,1
-	-	-	-	-	-	-	-

Equipment: 5x 230 V/16 A socket, 3x 230 V/16 A circuit breaker, 1/4" pneumatic quick-connect coupling; supplied without power cable (400 V / max 20 A) and pneumatic hose. Supplied **WITHOUT** the bracket for mounting between extension uprights. **Only for stationary workbenches.**

Order no. without pneum. quick coup.	Order no. with pneum. quick coup.	D x H mm	kg	Order no. without pneum. quick coup.	Order no. with pneum. quick coup.	D x H mm	kg
EN21	EN21P	-	-	EN21	EN21P	123 x 66	4,6
-	-	123 x 66	6,2	EN23	EN23P	-	-
EN21F	EN21FP	-	-	EN21F	EN21FP	123 x 66	4,6
-	-	123 x 66	6,2	EN23F	EN23FP	-	-

Equipment: 3x 230 V/16 A socket, 1x 230 V/16 A circuit breaker, 1/4" pneumatic quick-connect coupling, 1x 400 V/16 A socket, 1x 400 V/16 A circuit breaker; supplied without power cable (400 V / max 20 A) and pneumatic hose. Supplied **WITHOUT** the bracket for mounting between extension uprights. **Only for stationary workbenches.**

Order no. without pneum. quick coup.	Order no. with pneum. quick coup.	D x H mm	kg	Order no. without pneum. quick coup.	Order no. with pneum. quick coup.	D x H mm	kg
EN31	EN31P	-	-	EN31	EN31P	123 x 66	4,9
-	-	-	-	EN33	EN33P	-	-
EN31F	EN31FP	-	-	EN31F	EN31FP	123 x 66	4,9
-	-	-	-	EN33F	EN33FP	-	-

Equipment: 3x 230 V/16 A socket, 3x 230 V/16 A circuit breaker, 1/4" pneumatic quick-connect coupling, 230 V stop button, 1x 400 V/16 A socket, 1x 400 V/16 A circuit breaker, 1x 230 V/6 A circuit breaker, 230 V shunt trip; supplied without power cable (400 V / max 20 A) and pneumatic hose. Supplied **WITHOUT** the bracket for mounting between extension uprights. **Only for stationary workbenches.**



#### Attachment between uprights

Order number EKU3ESD

2 pcs per pack



The electric strip is fixed between the extension uprights using a bracket, **which is NOT included** in the package. We recommend adding a frame around the electric strip to fill the gap between the worktop and the electric strip.

Order number	kg	Order number	kg
8NV1	5	8NV1	5

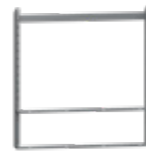
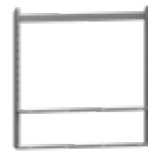

3 Electrical accessories

Lighting	Color	Width mm	width 1200 mm			width 1500 mm		
			Order number	D x H mm	kg	Order number	D x H mm	kg
	Natural Anodized	600	SLIMp30	136 x 26	2,0	SLIMp30	136 x 26	2,0
	Black Anodized	600	SLIMp30B	136 x 26	2,0	SLIMp30B	136 x 26	2,0
	Natural Anodized	1000	SLIMp58	136 x 26	2,4	SLIMp58	136 x 26	2,4
	Black Anodized	1000	SLIMp58B	136 x 26	2,4	SLIMp58B	136 x 26	2,4

Supplied without a lighting mount for the add-on arm.

Mounting for extension arm

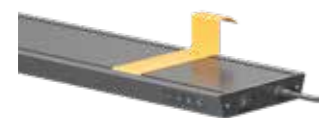

Order number	EKU5ESD
--------------	---------

2x cantilever brackets

Light electronics functions

Plus and Minus Buttons: Adjust the light output between 30% and 80%.  
**Button A:** Activates automatic regulation, which smoothly adjusts the lighting conditions at the workstation based on ambient light.  
**Button B:** Sets the light to maximum (100%) for 5 minutes before returning to the previous setting (80% output).

Technical description – SLIMp

An anodized full-aluminum housing with multifunctional longitudinal grooves. Powered at 230 V / 50 Hz with a power consumption of 58 W and 30 W, Mechanical switch, 3 m power cable, LG Innotek LED diodes, Micro-prismatic diffuser – low UGR, Light color – 4000 K color temperature, Capacitive touch control buttons.

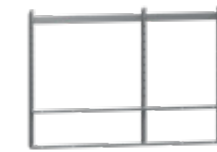
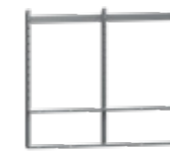

width 2000 mm			width 2500 mm		
Order number	D x H mm	kg	Order number	D x H mm	kg
SLIMp30	136 x 26	2,0	SLIMp30	136 x 26	2,0
SLIMp30B	136 x 26	2,0	SLIMp30B	136 x 26	2,0
SLIMp58	136 x 26	2,4	SLIMp58	136 x 26	2,4
SLIMp58B	136 x 26	2,4	SLIMp58B	136 x 26	2,4

Supplied without a lighting mount for the add-on arm.

Technical specifications – SLIMp58 luminaire

Output	Luminous flu	Power Consumption	Light Intensity (1.2 m above work surface)
100%	10 800 lm	58 W	2 750 lx
80%	8 640 lm	46 W	2 200 lx
50%	5 400 lm	29 W	1 380 lx
30%	3 250 lm	17 W	820 lx

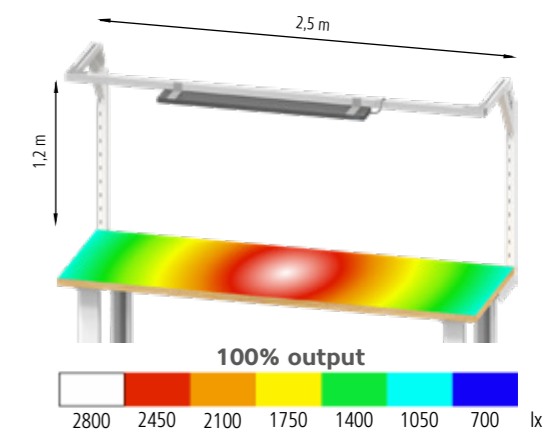

Electrical accessories and the electric strip frame can only be installed on stationary workbenches and cannot be used for mobile variants.

produced in Czechia



configurator | smfu.eu - manual



Using a cabinet extension, you can organize all your tools within just a few square meters. **The base of the cabinet extension for a worktop consists of supports on which the cabinets are placed.** The supports can be supplemented with perforated panels, and the entire extension can then be equipped with our hanging system and electrical accessories.

**It is recommended** to place the lighting under the extension cabinet using magnets. Both supports and cabinets are available in two width variants. **All components, including cabinets, supports, and panels, are part of the ESD program, which ensures protection against electrostatic discharge.**

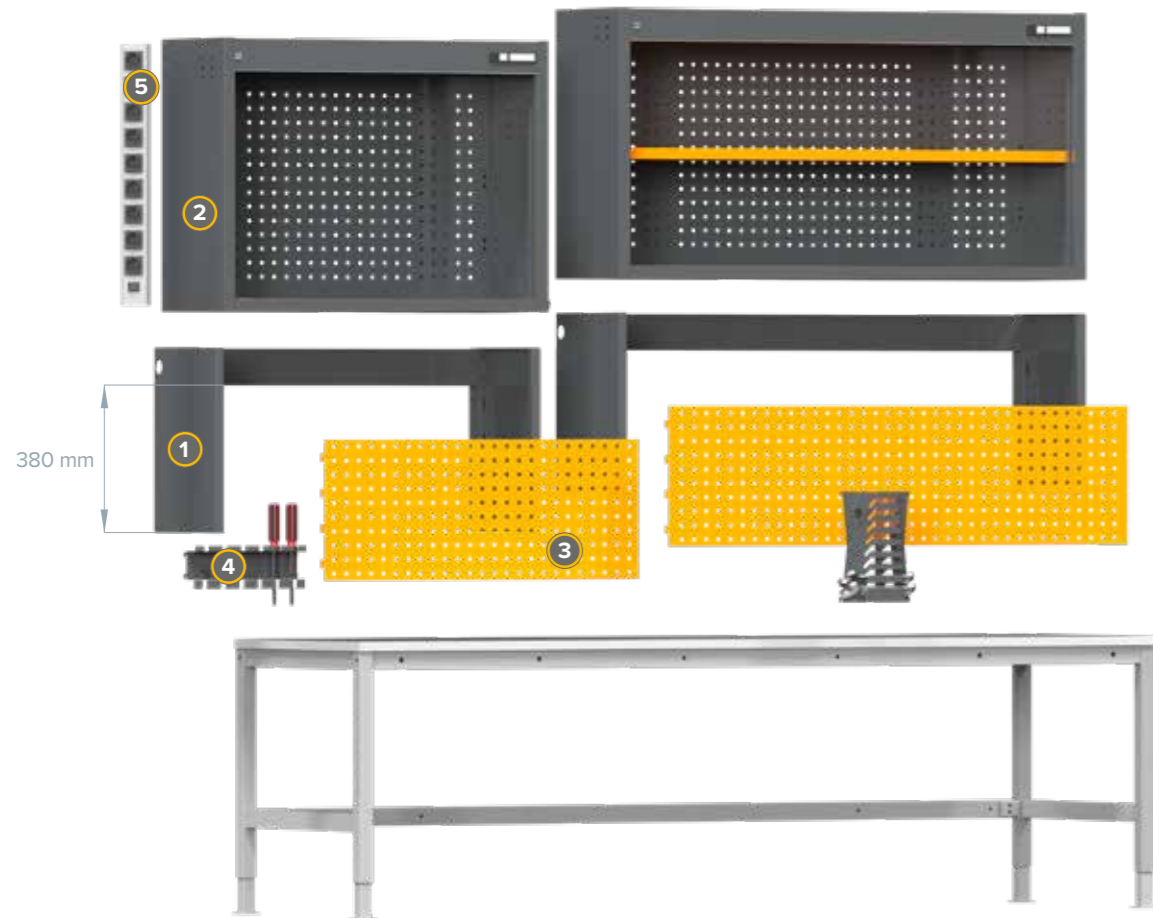

- 1** Extension supports  
Two widths: 1000 mm and 1500 mm; the support is finished with ESD paint and is screwed to the worktop, with the extension cabinet fixed onto it.
- 4** Hanging system  
A wide range of ESD variants available, from shelves to various tool holders and small hooks of different shapes.

- 2** Extension cabinet  
Two widths: 1000 mm and 1500 mm; equipped with a shelf inside and a perforated back. Finished with ESD paint.
- 5** Electrical accessories  
The extension can be equipped with lighting, an electric strip, or an extension cord.

- 3** Perforated / solid panels  
Suitable for filling the rear part of the support; used for hanging the hanging system (tool holders, hooks, etc.). Finished with ESD paint.

## Workbench extension variants



Order number	W x D x H
456142	300 x 500 x 200



Order number	W x D x H
456132	200 x 350 x 150



Order number	W x D x H
456122	145 x 235 x 125



Order number	W x D x H
456107	100 x 175 x 75



Order number	W x D x H
456102	100 x 100 x 60

## ESD plastic boxes

Plastic boxes are **manufactured from antistatic plastic**. They are designed with **semiconductive PP (dissipative) properties**, meeting the requirements of antistatic workplaces. The bottom of the box is designed for easier gripping of small items. **The boxes are equipped with a peripheral reinforcing rim for greater strength, a large recessed handle with space for a description label, and a rear hanging rail.**

## Hanging system

The ESD hanging system for the workbench extension offers a flexible and safe solution for workplace organization in electrostatically sensitive environments. It allows for a variable arrangement using support arms and a wide range of accessories, such as holders, panels, shelves, or ergonomic elements for the workplace. The result is a clear and modular system adaptable to specific needs.

 The hanging system range can be found on page 81.

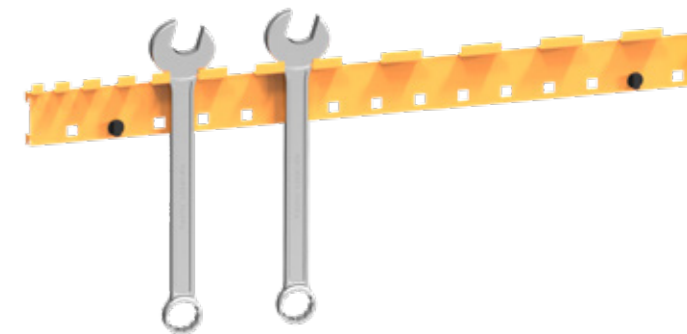

## Electrical accessories

Electrical accessories ensure the functionality and safe operation of the workplace. SLIMp lighting utilizes LED technology for high performance and low consumption in combination with high-quality aluminum construction. It also includes durable extension cords and electric strips with integrated protection, representing a reliable and universal solution for various applications.

 The electrical accessories range can be found on page 103.

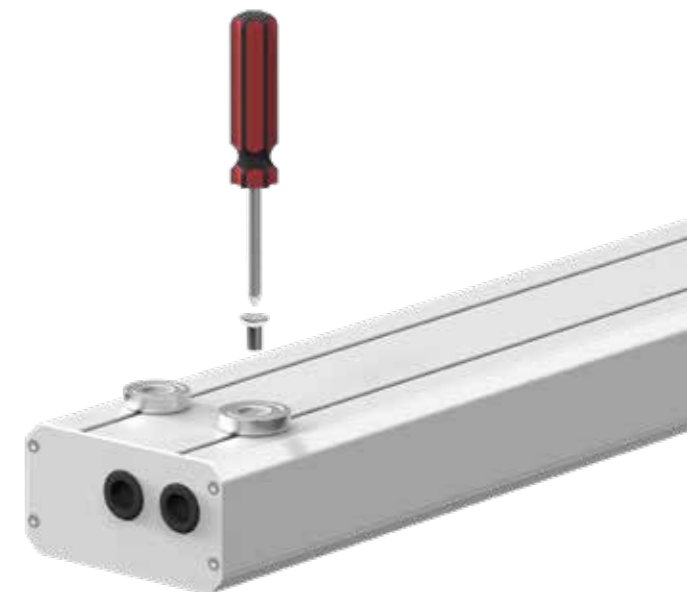



1 Superstructure frame

Cabinet base	H x D mm	Width mm	STATIONARY WORKBENCH depth 700 mm		STATIONARY WORKBENCH depth 800 mm	
			Order number	👤/⚖️ kg	Order number	👤/⚖️ kg
	500 x 350	1000	20SR5PESD	18/40	20SR5PESD	18/40
		1500	20SR5P2ESD	20/40	20SR5P2ESD	20/40



MOBILE WORKBENCH depth 700 mm		MOBILE WORKBENCH depth 800 mm	
Order number	👤/⚖️ kg	Order number	👤/⚖️ kg
20SR5PESD	18/40	20SR5PESD	18/40
20SR5P2ESD	20/40	20SR5P2ESD	20/40



In the case of choosing a workbench width of 1200 mm, it is not possible to add a 1500 mm wide cabinet support.

Cabinet width 1000 mm	W x D x H mm	Order number	👤/⚖️ kg	Order number	👤/⚖️ kg
	1000 x 350 x 500	20SR5ESD	28/40	20SR5ESD	28/40

Perforated back of the cabinet, 1x shelf finished with ESD paint, aluminum roller shutter with spring-loaded winding and an espagnolette lock.

Order number	👤/⚖️ kg	Order number	👤/⚖️ kg
20SR5ESD	28/40	20SR5ESD	28/40

Perforated back of the cabinet, 1x shelf finished with ESD paint, aluminum roller shutter with spring-loaded winding and an espagnolette lock.

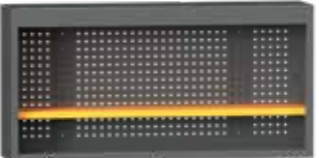
Cabinet width 1500 mm	W x D x H mm	Order number	👤/⚖️ kg	Order number	👤/⚖️ kg
	1500 x 350 x 500	20SR6ESD	32/40	20SR6ESD	32/40

Perforated back of the cabinet, 1x shelf finished with ESD paint, aluminum roller shutter with spring-loaded winding and an espagnolette lock.

Order number	👤/⚖️ kg	Order number	👤/⚖️ kg
20SR6ESD	32/40	20SR6ESD	32/40

Perforated back of the cabinet, 1x shelf finished with ESD paint, aluminum roller shutter with spring-loaded winding and an espagnolette lock.



2 Base equipment

Perforated panel	Height mm	width 1000 mm	
		Order number	👤 kg
		380	8NPP10ESD (max 1)
190	8NPP10HESD (max 2)	1,7	

Solid panel	Height mm	Order number	👤 kg	
		380	8NP10ESD (max 1)	3,0
		190	8NP10HESD (max 2)	1,7



width 1500 mm	
Order number	👤 kg
8NPP15ESD (max 1)	1,7
8NPP15HESD (max 2)	2,6

Order number	👤 kg
8NP15ESD (max 1)	1,7
8NP15HESD (max 2)	2,6



		width 1000 mm	
Cabinet shelf	Depth mm	Order number	kg
	206	20VPSR5ESD	2

		width 1000 mm	
Base shelf	Depth mm	Order number	kg
	206	8NPO10-1ESD	3,2
	370	8NPO10-2ESD	4,5

It is mounted to the uprights of the superstructure base frame.

### 3 Electrical accessories

		width 1000 mm			
Electric strip EN V1	Socket type	Order N. without pneum. quick coupling	Order N. with pneum. quick coupling	D x H mm	kg
	E (CZ)	EN11	EN11P	123 x 66	4,1
	F (DE)	EN11F	EN11FP	123 x 66	4,1

Equipment: 5x 230 V/16 A socket, 3x 230 V/16 A circuit breaker, 1/4" pneumatic quick-connect coupling; supplied without power cable (400 V / max 20 A) and pneumatic hose. Supplied WITHOUT the electric strip bracket.

		width 1000 mm			
Electric strip EN V2	Socket type	Order N. without pneum. quick coupling	Order N. with pneum. quick coupling	D x H mm	kg
	E (CZ)	EN21	EN21P	123 x 66	4,1
	F (DE)	EN21F	EN21FP	123 x 66	4,1

Equipment: 3x 230 V/16 A socket, 1x 230 V/16 A circuit breaker, 1/4" pneumatic quick-connect coupling, 1x 400 V/16 A socket, 1x 400 V/16 A circuit breaker; supplied without power cable (400 V / max 20 A) and pneumatic hose. Supplied WITHOUT the electric strip bracket.

		width 1000 mm			
Electric strip EN V3	Socket type	Order N. without pneum. quick coupling	Order N. with pneum. quick coupling	D x H mm	kg
	E (CZ)	EN31	EN31P	123 x 66	4,1
	F (DE)	EN31F	EN31FP	123 x 66	4,1

Equipment: 3x 230 V/16 A socket, 3x 230 V/16 A circuit breaker, 1/4" pneumatic quick-connect coupling, 230 V stop button, 1x 400 V/16 A socket, 1x 400 V/16 A circuit breaker, 1x 230 V/6 A circuit breaker, 230 V shunt trip; supplied without power cable (400 V / max 20 A) and pneumatic hose. Supplied WITHOUT the electric strip bracket.



Type E sockets for the Czech Republic and other countries



Type F sockets for Germany and other countries



		width 1500 mm	
	Order number	kg	
	20VPSR6ESD	3	

		width 1500 mm	
	Order number	kg	
	8NPO15-1ESD	5,0	
	8NPO15-2ESD	7,0	

		width 1500 mm			
	Order N. without pneum. quick coupling	Order N. with pneum. quick coupling	D x H mm	kg	
	EN13	EN13P	123 x 66	5,6	
	EN13F	EN13FP	123 x 66	5,6	

Equipment: 5x 230 V/16 A socket, 3x 230 V/16 A circuit breaker, 1/4" pneumatic quick-connect coupling; supplied without power cable (400 V / max 20 A) and pneumatic hose. Supplied WITHOUT the electric strip bracket.

		width 1500 mm			
	Order N. without pneum. quick coupling	Order N. with pneum. quick coupling	D x H mm	kg	
	EN23	EN23P	123 x 66	5,6	
	EN23F	EN23FP	123 x 66	5,6	

Equipment: 3x 230 V/16 A socket, 1x 230 V/16 A circuit breaker, 1/4" pneumatic quick-connect coupling, 1x 400 V/16 A socket, 1x 400 V/16 A circuit breaker; supplied without power cable (400 V / max 20 A) and pneumatic hose. Supplied WITHOUT the electric strip bracket.

		width 1500 mm			
	Order N. without pneum. quick coupling	Order N. with pneum. quick coupling	D x H mm	kg	
	EN33	EN33P	123 x 66	5,6	
	EN33F	EN33FP	123 x 66	5,6	

Equipment: 3x 230 V/16 A socket, 3x 230 V/16 A circuit breaker, 1/4" pneumatic quick-connect coupling, 230 V stop button, 1x 400 V/16 A socket, 1x 400 V/16 A circuit breaker, 1x 230 V/6 A circuit breaker, 230 V shunt trip; supplied without power cable (400 V / max 20 A) and pneumatic hose. Supplied WITHOUT the electric strip bracket.



#### Attachment between uprights

Order number	EKU3ESD
	2 pcs per pack



The electric strip is fixed to the extension support using a bracket, which is NOT included in the package. We recommend adding a frame around the electric strip to fill the gap between the worktop and the electric strip.



3 Electrical accessories

		width 1000 mm		
Lighting	Color	Order number	W x D x H mm	kg
	Natural anodized	SLIMp30	600 x 136 x 26	2,0
	Black anodized	SLIMp30B	600 x 136 x 26	2,0

Supplied without mounting bracket for the superstructure arm.

Magnetic mounting



Order number
EKU2

4x magnet

Light electronics functions

Plus and Minus Buttons: Adjust the light output between 30% and 80%.

**Button A:** Activates automatic regulation, which smoothly adjusts the lighting conditions at the workstation based on ambient light.

**Button B:** Sets the light to maximum (100%) for 5 minutes before returning to the previous setting (80% output).

Technical description – SLIMp

An anodized full-aluminum housing with multifunctional longitudinal grooves. Powered at 230 V / 50 Hz with a power consumption of 58 W and 30 W, Mechanical switch, 3 m power cable, LG Innotek LED diodes, Micro-prismatic diffuser – low UGR, Light color – 4000 K color temperature, Capacitive touch control buttons.



width 1500 mm		
Order number	W x D x H mm	kg
SLIMp58	1000 x 136 x 26	2,4
SLIMp58B	1000 x 136 x 26	2,4

Supplied without mounting bracket for the superstructure arm.

Technical specifications – SLIMp58 luminaire

Output	Luminous flu	Power Consumption	Light Intensity (1.2 m above work surface)
100%	10 800 lm	58 W	2 750 lx
80%	8 640 lm	46 W	2 200 lx
50%	5 400 lm	29 W	1 380 lx
30%	3 250 lm	17 W	820 lx

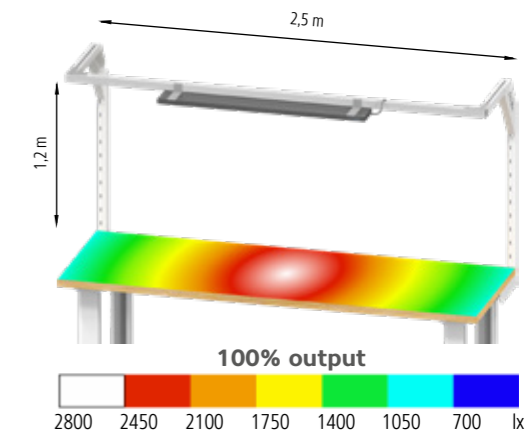

80+ CRI, covered protection IP20, electromagnetic compatibility EMC, CE

produced in Czechia



configurator | smfu.eu - manual

### Hanging system



The 10 kg arm can be mounted at any height on the posts.. Select the appropriate equipment variant below.

#### ESD Arm 10 kg

Order number	kg	kg
20ERY1ESD	10	3

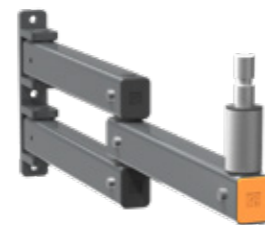

The 30 kg arm can be mounted on posts at one fixed height. Select the appropriate equipment variant below.

#### ESD Arm 30 kg

Order number	kg	kg
20ERY2ESD	30	4

### ESD plastic boxes



Order number	W x D x H
456142	300 x 500 x 200



Order number	W x D x H
456132	200 x 350 x 150

Plastic boxes are manufactured from antistatic plastic. They are designed with **semiconductive PP (dissipative) properties**, meeting the requirements of antistatic workplaces. The bottom of the box is designed for easier gripping of small items. **The boxes are equipped with a peripheral reinforcing rim for greater strength**, a large recessed handle with space for a description label, and a rear hanging rail.



Order number	W x D x H
456122	145 x 235 x 125



Order number	W x D x H
456107	100 x 175 x 75



Order number	W x D x H
456102	100 x 100 x 60

### Hanging system

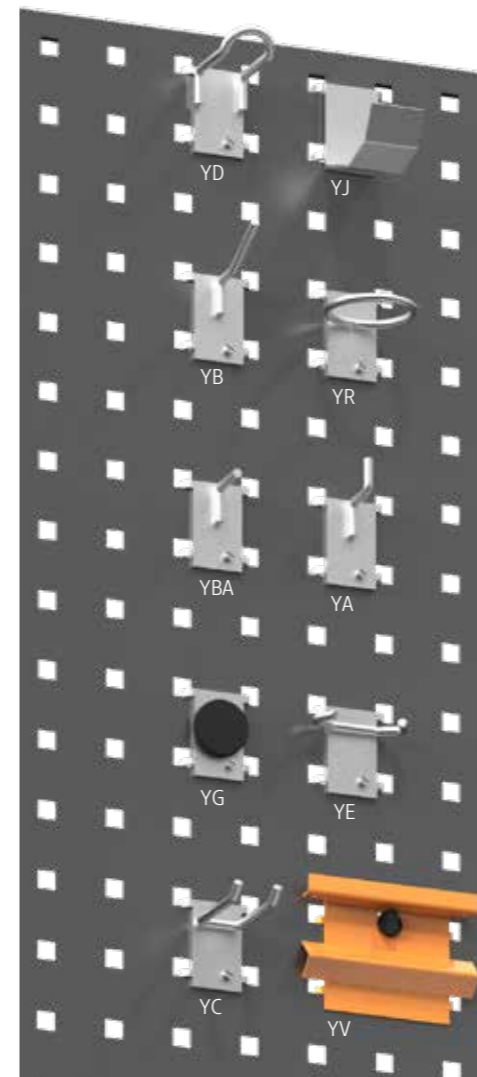

#### Loop hook

Order number	W x D mm
YD1	25 x 35
YD2	25 x 100

#### Flat hook

Order number	D mm
YJ1	60
YJ2	100

#### Single bent hook

Order number	D mm
YB1	25 + 35
YB2	15 + 70

#### Circular hook

Order number	Průměr mm
YR1	40
YR2	60
YR3	80
YR4	100

#### Straight hook

Order number	D mm
YBA1	20
YBA2	50
YBA3	90
YBA4	140

#### Single hook

Order number	D mm
YA1	15
YA2	90
YA3	140

#### Magnet

Order number	Průměr mm
YG1	30

#### Double bent hook

Order number	W x D mm
YC1	15 x 45
YC2	15 x 90
YC3	30 x 35
YC4	45 x 35
YC5	45 x 90

#### Plastic box holder

Order number	W x D mm
YV1ESD	590 x 70
YV2ESD	100 x 70
YV3LESD	410 x 70
YV3PESD	410 x 70

Type YV3 is designed for left and right doors of SK1 and SK2 cabinets

#### C Hook

Order number	W x D mm
YE1	45 + 25



#### ESD Fork with perforated panel

Order number	kg
20ERY3ESD	5

The perforated panel can be mounted on both sides of the fork.

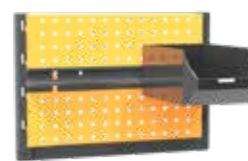

#### ESD Fork with box holders

Order number	kg
20ERY4ESD	5,5

The perforated panel can be mounted on both sides of the fork; the box is not included.



#### ESD Fork with foldable shelf

Order number	kg
20ERY5ESD	7



#### ESD Monitor and keyboard holder

Order number	Holder construction	kg
20ERY6ESD	For monitor	1
20ERY7ESD	For keyboard	3
20ERY8ESD	For monitor and keyboard	4



#### ESD Fixed shelf

Order number	kg
20ERY9ESD	5

Placed on the arm



#### ESD Shelf

Order number	kg
20NPO6EESD	2

Placed on the fork



#### ESD Fork

Order number	kg
20ERY10ESD	3,3

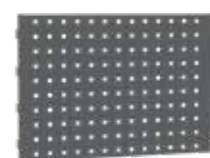

#### ESD Perforated panel

Order number	kg
20NPP6EESD	1,7

Can be placed on both sides of the fork



#### ESD Foldable shelf

Order number	kg
20ERY52ESD	3,5

Max. 2x per fork



#### ESD Box holder

Order number	W x D mm
20YV4ESD	550 x 70

Can only be placed on a perforated panel

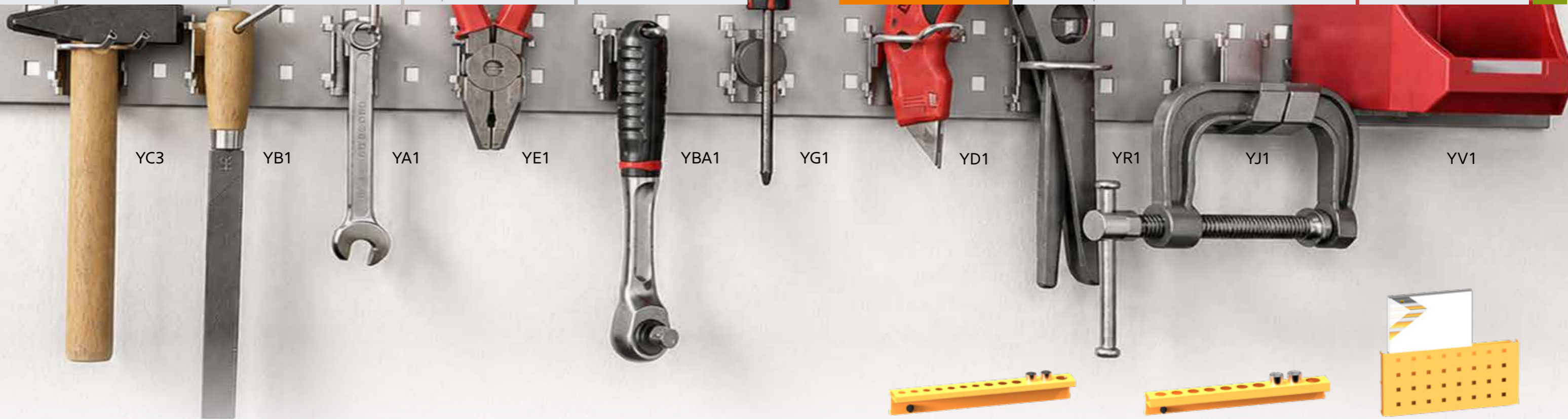

YC3

YB1

YA1

YE1

YBA1

YG1

YD1

YR1

YJ1

YV1

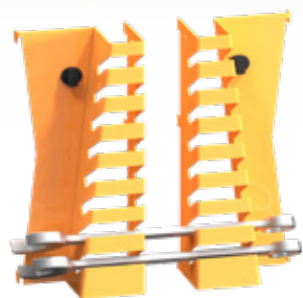

For stable placement of large wrenches, holders can be mounted farther apart.



ESD Horizontal wrench holder

Order number	W x D x H mm
YPL1ESD	144 x 200 x 40

Supplied in pairs



To store more smaller wrenches, holders can be separated into two individual mounts.

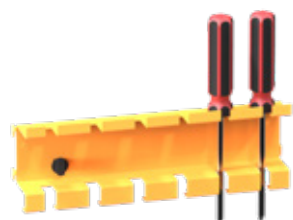

ESD Screwdriver holder

Order number	W mm
YX1ESD	228
YX2ESD	340



ESD Punch holder

Order number	W mm
YL1ESD	190



ESD Allen key holder

Order number	W mm
YN1ESD	190



ESD 1/4" Socket holder

Order number	W mm
YH1ESD	342



ESD 1/2" Socket holder

Order number	W mm
YK1ESD	380

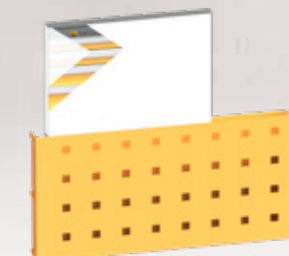

ESD Storage tray

Order number	W x D x H mm
YQ1ESD	342 x 19 x 163

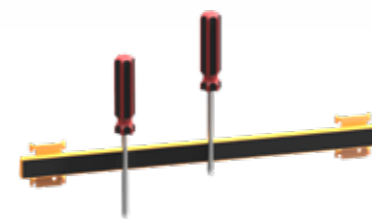

ESD Magnetic strip

Order number	W mm	kg
YSM1ESD	415	2,5



ESD Arc bracket

Order number	W x D mm
YM1ESD	142 x 103

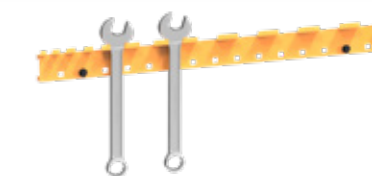

ESD Vertical wrench holder

Order number	W mm
YZ1ESD	609



ESD Shelf system rail

Order number	W mm
YAL1ESD	910
YAL2ESD	1900
YAL3ESD	2400

Support rail is supplied without shelf.

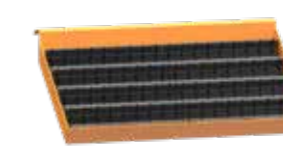

ESD Shelf

Order number	W x D mm
YALK1ESD	307 x 152

POLAK plastic dividers (see page 39) can be inserted into the shelf. Shelf is supplied without dividers.



ESD Hanging shelf

Order number	W x D mm
8YF1ESD	380 x 100

Ergonomic workplaces





**ERGO workplace 240**

Height-adjustable workplaces with a leg load capacity of **240 kg** are an economically affordable variant of electrically adjustable workbenches. **The workbenches excel with a robust frame for absolute rigidity, maximum load capacity, and workplace stability.** The upright extension allows for the hanging of two rows of perforated panels and a wide range of mutually interchangeable elements of the hanging system with an arm load capacity of **10 kg**. These workbenches are a suitable

variant for creating light assembly workplaces. **All components and construction, except for the workbench legs, are ESD conductive.**

Technical specifications of the worktop according to IEC 61340-5-1	
Volume resistance $R_d$	$1 \times 10^4 - 1 \times 10^9$ Ohm
Measurement conditions: 20% RH, 20-30°C, 96h	

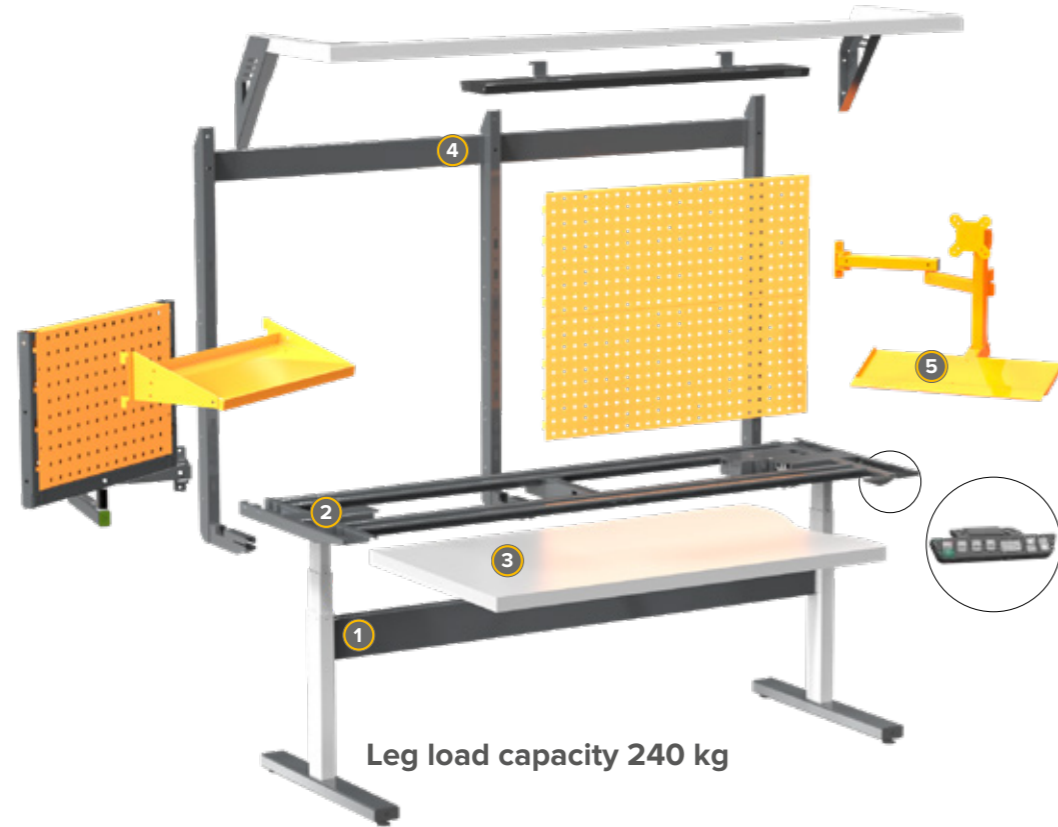

**Leg load capacity 240 kg**

- 1** Table legs, load capacity 240 kg electrically adjustable legs, in three widths: 1500, 2000, and 2500 mm, without the possibility of a suspended cabinet; the legs **are not** finished with ESD paint
- 4** Extension uprights for max. 2 panels, possibility of adding an arm, electrical accessories, and hanging system; finished with ESD paint

- 2** Support frame **robust ESD frame for the worktop for absolute rigidity, maximum load capacity, and workplace stability**
- 5** Hanging system arms for Ergo workplaces, tool and box holders, hooks of various sizes, magnetic strips, and more; finished with ESD paint

- 3** Worktop antistatic worktop with a conductive core, equipped with a grounding terminal and a protective resistor for connecting an ESD wrist strap

**Variants of ERGO workplaces 240**

Electrically adjustable legs, 1500 mm

Electrically adjustable legs, 2000 mm

Electrically adjustable legs, 2500 mm

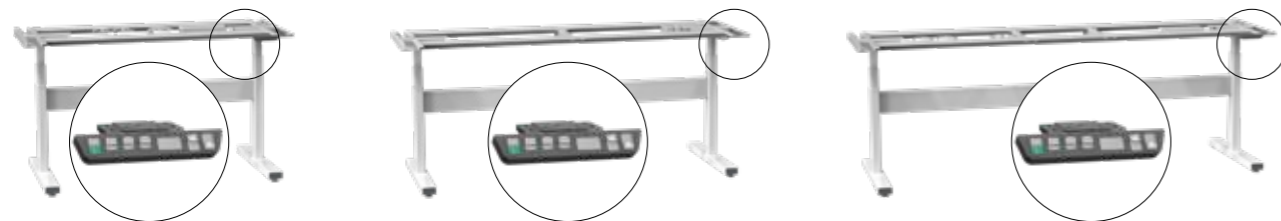

**ERGO workplace 400**

Height-adjustable workbenches with a leg load capacity of **400 kg** are a suitable solution for creating individual and system workplaces. These workbenches can be equipped with three types of legs (adjustable in increments of 15 mm, continuous manual crank, or electrical). **The workbenches excel with a robust frame for absolute rigidity, maximum load capacity, and workplace stability.** The upright extension allows for the hanging of three rows of perforated panels and a wide range of mutually interchangeable elements of the hanging system

with an arm load capacity of 30 or 10 kg. **All components and construction, except for the workbench legs, are ESD conductive.**

Technical specifications of the worktop according to IEC 61340-5-1	
Volume resistance $R_d$	$1 \times 10^4 - 1 \times 10^9$ Ohm
Measurement conditions: 20% RH, 20-30°C, 96h	

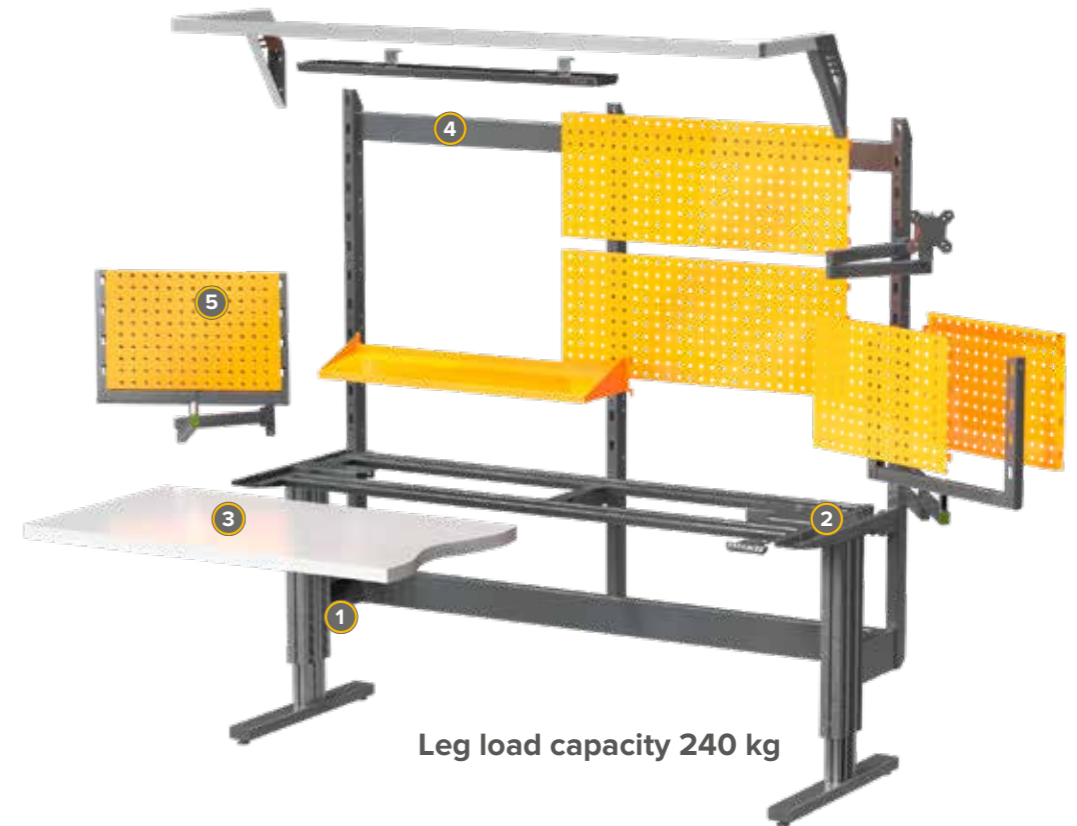

**Leg load capacity 240 kg**

- 1** Table legs, load capacity 400 kg incremental, crank, and electrically adjustable legs in three widths: 1500, 2000, and 2500 mm; legs **are not** finished with ESD paint
- 4** Extension uprights for 3 panels above each other, possibility of adding an arm, electrical accessories, and hanging system; finished with ESD paint

- 2** Support frame **robust ESD frame for the worktop for absolute rigidity, maximum load capacity, and workplace stability**
- 5** Hanging system arms for Ergo workplaces, tool and box holders, hooks of various sizes, magnetic strips, and more; finished with ESD paint

- 3** Worktop antistatic worktop with a conductive core, equipped with a grounding terminal and a protective resistor for connecting an ESD wrist strap

**Variants of ERGO workplaces 400**

Incremental adjustable legs, 3 widths

Crank adjustable legs, 3 widths

Electrically adjustable legs, 3 widths



## Standard configuration



Incremental adjustable ERGO workbench 400 with extension

Worktop	Order number	W mm	H mm	kg	kg
laminated 25 mm	20ERGO5NESD	2000	770 - 1170	260	147

Incremental adjustable legs in 15 mm steps using screws, supporting frame under the worktop, work surface depth 700 mm, upright extension, 6x perforated panel, extension arm



Crank adjustable ERGO workbench 400 with extension

Worktop	Order number	W mm	H mm	kg	kg
laminated 25 mm	20ERGO11NESD	2000	790 - 1100	240	164

Continuously crank adjustable legs, supporting frame under the worktop, work surface depth 700 mm, upright extension, 6x perforated panel, extension arm; the construction does not allow for a suspended drawer cabinet

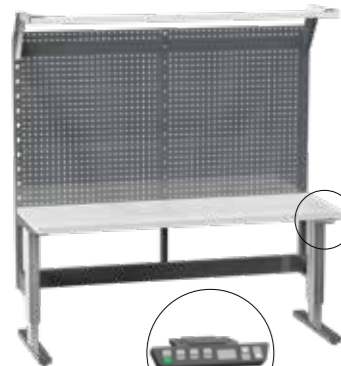

Electrically adjustable ERGO workbench 400 with extension

Worktop	Order number	W mm	H mm	kg	kg
laminated 25 mm	20ERGO17NESD	2000	770 - 1170	260	151

Continuously electrically adjustable legs, supporting frame under the worktop, work surface depth 700 mm, upright extension, 6x perforated panel, extension arm



Electrically adjustable ERGO workbench 240 with extension

Worktop	Order number	W mm	H mm	kg	kg
laminated 25 mm	20ERGO23NESD	2000	660 - 1100	130	133

Continuously electrically adjustable legs, supporting frame under the worktop, work surface depth 700 mm, upright extension, 4x perforated panel, extension arm

## Standard configuration



Incremental adjustable ERGO workbench 400

Worktop	Order number	W mm	H mm	kg	kg
laminated 25 mm	20ERGO4ESD	1500	770 - 1170	325	82,5
laminated 25 mm	20ERGO5ESD	2000	770 - 1170	300	100,0
laminated 25 mm	20ERGO6ESD	2500	770 - 1170	275	116,5

Incremental adjustable legs in 15 mm steps using screws, supporting frame under the worktop, work surface depth 700 mm

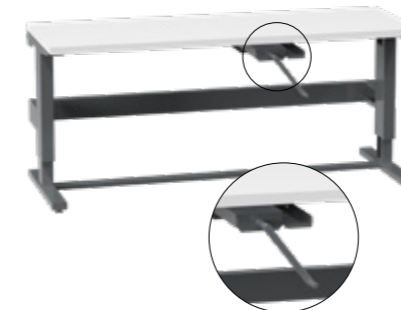

Crank adjustable ERGO workbench 400

Worktop	Order number	W mm	H mm	kg	kg
laminated 25 mm	20ERGO10ESD	1500	790 - 1100	300	99,5
laminated 25 mm	20ERGO11ESD	2000	790 - 1100	275	117,0
laminated 25 mm	20ERGO12ESD	2500	790 - 1100	250	133,5

Continuously crank adjustable legs, supporting frame under the worktop, work surface depth 700 mm; the construction does not allow for a suspended drawer cabinet



Electrically adjustable ERGO workbench 400

Worktop	Order number	W mm	H mm	kg	kg
laminated 25 mm	20ERGO16ESD	1500	770 - 1170	325	86,5
laminated 25 mm	20ERGO17ESD	2000	770 - 1170	300	104,0
laminated 25 mm	20ERGO18ESD	2500	770 - 1170	275	120,5

Continuously electrically adjustable legs, supporting frame under the worktop, work surface depth 700 mm



Electrically adjustable ERGO workbench 240

Worktop	Order number	W mm	H mm	kg	kg
laminated 25 mm	20ERGO22ESD	1500	660 - 1100	190	73,5
laminated 25 mm	20ERGO23ESD	2000	660 - 1100	175	89,0
laminated 25 mm	20ERGO24ESD	2500	660 - 1100	160	104,0

Continuously electrically adjustable legs, supporting frame under the worktop, work surface depth 700 mm; the construction does not allow for a suspended drawer cabinet



**1 Table equipment**

**Drawer cabinet 27 x 27D**



Drawer Arrangement
100E, 200E
100E, 100E, 100E
75E, 100E, 125E

Depth x width: 630 x 578 mm

ERGO table 240 electrically adjustable			
Order number	H mm	kg	
-	-	-	-
-	-	-	-
-	-	-	-

**2 Extension construction**

**Extension for ERGO 240**



Height mm	Width mm
1142	1500
	2000
	2500
762	1500
	2000
	2500
382	1500
	2000
	2500

ERGO table 240 electrically adjustable					
Order number	Number of panels	kg	kg		
20NS10EESD	2	60	12,5		
20NS11EESD	4	60	18		
20NS12EESD	4	60	19		
20NS10E-2ESD	2	60	11,5		
20NS11E-2ESD	4	60	17		
20NS12E-2ESD	4	60	18		
20NS10E-1ESD	1	30	8,5		
20NS11E-1ESD	2	30	14		
20NS12E-1ESD	2	30	15		

**Extension for ERGO 400**



Height mm	Width mm
1142	1500
	2000
	2500
762	1500
	2000
	2500
382	1500
	2000
	2500

ERGO table 240 electrically adjustable					
Order number	Number of panels	kg	kg		
-	-	-	-		
-	-	-	-		
-	-	-	-		
-	-	-	-		
-	-	-	-		
-	-	-	-		
-	-	-	-		
-	-	-	-		
-	-	-	-		



ERGO table 400 stepwise adjustable		
Order number	H mm	kg
ZA39-2ERGOESD	390	34
ZA39-3ERGOESD	390	40
ZA39-4ERGOESD	390	40

ERGO table 400 hand crank adjustable		
Order number	H mm	kg
-	-	-
-	-	-
-	-	-

ERGO table 400 electrically adjustable		
Order number	H mm	kg
ZA39-2ERGOESD	390	34
ZA39-3ERGOESD	390	40
ZA39-4ERGOESD	390	40

Depth x width: 630 x 578 mm

ERGO table 400 stepwise adjustable			
Order number	Number of panels	kg	kg
-	-	-	-
-	-	-	-
-	-	-	-
-	-	-	-
-	-	-	-
-	-	-	-
-	-	-	-
-	-	-	-
-	-	-	-
-	-	-	-

ERGO table 400 hand crank adjustable			
Order number	Number of panels	kg	kg
-	-	-	-
-	-	-	-
-	-	-	-
-	-	-	-
-	-	-	-
-	-	-	-
-	-	-	-
-	-	-	-
-	-	-	-
-	-	-	-

ERGO table 400 electrically adjustable			
Order number	Number of panels	kg	kg
-	-	-	-
-	-	-	-
-	-	-	-
-	-	-	-
-	-	-	-
-	-	-	-
-	-	-	-
-	-	-	-
-	-	-	-
-	-	-	-

ERGO table 400 stepwise adjustable			
Order number	Number of panels	kg	kg
20NS7EESD	3	120	14
20NS8EESD	6	120	21
20NS9EESD	6	120	22
20NS7E-2ESD	2	120	13
20NS8E-2ESD	4	120	20
20NS9E-2ESD	4	120	21
20NS7E-1ESD	1	60	10
20NS8E-1ESD	2	60	17
20NS9E-1ESD	2	60	18

ERGO table 400 hand crank adjustable			
Order number	Number of panels	kg	kg
20NS7EESD	3	120	14
20NS8EESD	6	120	21
20NS9EESD	6	120	22
20NS7E-2ESD	2	120	13
20NS8E-2ESD	4	120	20
20NS9E-2ESD	4	120	21
20NS7E-1ESD	1	60	10
20NS8E-1ESD	2	60	17
20NS9E-1ESD	2	60	18

ERGO table 400 electrically adjustable			
Order number	Number of panels	kg	kg
20NS7EESD	3	120	14
20NS8EESD	6	120	21
20NS9EESD	6	120	22
20NS7E-2ESD	2	120	13
20NS8E-2ESD	4	120	20
20NS9E-2ESD	4	120	21
20NS7E-1ESD	1	60	10
20NS8E-1ESD	2	60	17
20NS9E-1ESD	2	60	18



**Extension arm with aluminum profil**



Width mm	Order number	kg	kg
1500	8ALNR15ESD	6	6,2
2000	8ALNR20ESD	6	7,2
2500	8ALNR25ESD	6	8,1

**Extension arm with pneumatic quick coupler**



Width mm	Order number	kg	kg
1500	8ALNRPN15ESD	6	7,4
2000	8ALNRPN20ESD	6	8,3
2500	8ALNRPN25ESD	6	9,2

Arms are delivered without the superstructure frame. Aluminum profile size 40 x 40 mm with grooves for T8 nuts. Pneumatic quick coupler can be mounted on either side of the arm and cannot be ordered separately later



The arm profile is made of aluminum, which makes it stand out for its lightness and, above all, strength. The arm is adjustable by 130 mm. The hanging system range for workbench extensions can be found on page 81.

**Hanging trolley**



W x D x H mm	Order number	kg
35 x 60 x 20	8NV1	5



**3 Extension equipment**

**Perforated panel**



Height mm	Width mm	ERGO 240 width 1500 mm		ERGO 240 width 2000 mm	
		Order number	kg	Order number	kg
380	1000	-	-	8NPP10ESD	3
380	1500	8NPP15ESD (max 2)	4,7	-	-
190	1000	-	-	8NPP10HESD	1,7
190	1500	8NPP15HESD (max 4)	2,6	-	-



Order number	kg	kg	Order number	kg	kg	Order number	kg	kg
8ALNR15ESD	6	6,2	8ALNR15ESD	6	6,2	8ALNR15ESD	6	6,2
8ALNR20ESD	6	7,2	8ALNR20ESD	6	7,2	8ALNR20ESD	6	7,2
8ALNR25ESD	6	8,1	8ALNR25ESD	6	8,1	8ALNR25ESD	6	8,1

Order number	kg	kg	Order number	kg	kg	Order number	kg	kg
8ALNRPN15ESD	6	7,4	8ALNRPN15ESD	6	7,4	8ALNRPN15ESD	6	7,4
8ALNRPN20ESD	6	8,3	8ALNRPN20ESD	6	8,3	8ALNRPN20ESD	6	8,3
8ALNRPN25ESD	6	9,2	8ALNRPN25ESD	6	9,2	8ALNRPN25ESD	6	9,2

Arms are delivered without the superstructure frame. Aluminum profile size 40 x 40 mm with grooves for T8 nuts. Pneumatic quick coupler can be mounted on either side of the arm and cannot be ordered separately later



When choosing an extension of a specific width, it is necessary to select an arm of the corresponding size. Combining elements with different widths is not possible for construction reasons.

Order number	kg	Order number	kg	Order number	kg
8NV1	5	8NV1	5	8NV1	5



ERGO 240 width 2500 mm		ERGO 400 width 1500 mm		ERGO 400 width 2000 mm		ERGO 400 width 2500 mm	
Order number	kg	Order number	kg	Order number	kg	Order number	kg
8NPP10ESD (max 2)	3	-	-	8NPP10ESD (max 6)	3	8NPP10ESD (max 3)	3
8NPP15ESD (max 2)	4,7	8NPP15ESD (max 3)	4,7	-	-	8NPP15ESD (max 3)	4,7
8NPP10HESD (max 4)	1,7	-	-	8NPP10HESD (max 12)	1,7	8NPP10HESD (max 6)	1,7
8NPP15HESD (max 4)	2,6	8NPP15HESD (max 6)	2,6	-	-	8NPP15HESD (max 6)	2,6



Solid panel	Height mm	Width mm	ERGO 240 width 1500 mm		ERGO 240 width 2000 mm	
			Order number	kg	Order number	kg
	380	1000	-	-	8NP10ESD (max 6)	3,0
	380	1500	8NP15ESD (max 3)	4,7	-	-

Electric strip frame	Height mm	Width mm	ERGO 240 width 1500 mm		ERGO 240 width 2000 mm	
			Order number	kg	Order number	kg
	190	1000	-	-	8NPR10ESD	1,0
	190	1500	8NPR15ESD	1,9	-	-

Shelf	Depth mm	Width mm	ERGO 240 width 1500 mm		ERGO 240 width 2000 mm	
			Order number	kg	Order number	kg
	206	1000	-	-	8NPO10-1ESD	3,2
	206	1500	8NPO15-1ESD	4,5	-	-
	370	1000	-	-	8NPO10-2ESD	5,0
	370	1500	8NPO15-2ESD	7,0	-	-

Arm	load capacity kg	ERGO 240 width 1500 mm		ERGO 240 width 2000 mm	
		Order number	kg	Order number	kg
	10	20ERY1ESD	3	20ERY1ESD	3
	30	-	-	-	-



ERGO 240 width 2500 mm		ERGO 400 width 1500 mm		ERGO 400 width 2000 mm		ERGO 400 width 2500 mm	
Order number	kg	Order number	kg	Order number	kg	Order number	kg
8NP10ESD (max 3)	3,0	-	-	8NP10ESD (max 6)	3,0	8NP10ESD (max 3)	3,0
8NP15ESD (max 3)	4,7	8NP15ESD (max 3)	4,7	-	-	8NP15ESD (max 3)	4,7

ERGO 240 width 2500 mm		ERGO 400 width 1500 mm		ERGO 400 width 2000 mm		ERGO 400 width 2500 mm	
Order number	kg	Order number	kg	Order number	kg	Order number	kg
8NPR10ESD	1,0	-	-	8NPR10ESD	1,0	8NPR10ESD	1,0
8NPR15ESD	1,9	8NPR15ESD	1,9	-	-	8NPR15ESD	1,9

ERGO 240 width 2500 mm		ERGO 400 width 1500 mm		ERGO 400 width 2000 mm		ERGO 400 width 2500 mm	
Order number	kg	Order number	kg	Order number	kg	Order number	kg
8NPO10-1ESD	3,2	-	-	8NPO10-1ESD	3,2	8NPO10-1ESD	3,2
8NPO15-1ESD	4,5	8NPO15-1ESD	4,5	-	-	8NPO15-1ESD	4,5
8NPO10-2ESD	5,0	-	-	8NPO10-2ESD	5,0	8NPO10-2ESD	5,0
8NPO15-2ESD	7,0	8NPO15-2ESD	7,0	-	-	8NPO15-2ESD	7,0

ERGO 240 width 2500 mm		ERGO 400 width 1500 mm		ERGO 400 width 2000 mm		ERGO 400 width 2500 mm	
Order number	kg	Order number	kg	Order number	kg	Order number	kg
20ERY1ESD	3	20ERY1ESD	3	20ERY1ESD	3	20ERY1ESD	3
-	-	20ERY2ESD	4	20ERY2ESD	4	20ERY2ESD	4



An ergonomic arm with a load capacity of 10 kg can be attached to the extension uprights at any height. An arm with a load capacity of 30 kg can be attached to the extension uprights at only one height (above the worktop).



Only 2 perforated or solid panels can be placed above each other on the extension of the ERGO workplace 240. 3 panels can be placed above each other on the extension for workplace 400.



**4 Electrical accessories**

**Electric strip EN V1**



Socket type	Width mm	ERGO 240 width 1500 mm				ERGO 240 width 2000 mm			
		Order N. without pneum. quick coupling	Order N. with pneum. quick coupling	D x H mm	kg	Order N. without pneum. quick coupling	Order N. with pneum. quick coupling	D x H mm	kg
E (CZ)	934	-	-	-	-	EN11	EN11P	123 x 66	4,1
E (CZ)	1414	EN13	EN13P	123 x 66	5,6	-	-	-	-
F (DE)	934	-	-	-	-	EN11F	EN11FP	123 x 66	4,1
F (DE)	1414	EN13F	EN13FP	123 x 66	5,6	-	-	-	-

Equipment: 5x 230 V/16 A socket, 3x 230 V/16 A circuit breaker, 1/4" pneumatic quick-connect coupling; supplied without power cable (400 V / max 20 A) and pneumatic hose. Supplied **WITHOUT** the bracket for mounting between uprights.

**Electric strip EN V2**



Socket type	Width mm	ERGO 240 width 1500 mm				ERGO 240 width 2000 mm			
		Order N. without pneum. quick coupling	Order N. with pneum. quick coupling	D x H mm	kg	Order N. without pneum. quick coupling	Order N. with pneum. quick coupling	D x H mm	kg
E (CZ)	934	-	-	-	-	EN21	EN21P	123 x 66	4,6
E (CZ)	1414	EN23	EN23P	123 x 66	6,2	-	-	-	-
F (DE)	934	-	-	-	-	EN21F	EN21FP	123 x 66	4,6
F (DE)	1414	EN23F	EN23FP	123 x 66	6,2	-	-	-	-

Equipment: 3x 230 V/16 A socket, 1x 230 V/16 A circuit breaker, 1/4" pneumatic quick-connect coupling, 1x 400 V/16 A socket, 1x 400 V/16 A circuit breaker; supplied without power cable (400 V / max 20 A) and pneumatic hose. Supplied **WITHOUT** the bracket for mounting between uprights.

**Electric strip EN V3**



Socket type	Width mm	ERGO 240 width 1500 mm				ERGO 240 width 2000 mm			
		Order N. without pneum. quick coupling	Order N. with pneum. quick coupling	D x H mm	kg	Order N. without pneum. quick coupling	Order N. with pneum. quick coupling	D x H mm	kg
E (CZ)	934	-	-	-	-	EN31	EN31P	123 x 66	4,9
E (CZ)	1414	EN33	EN33P	123 x 66	6,5	-	-	-	-
F (DE)	934	-	-	-	-	EN31F	EN31FP	123 x 66	4,9
F (DE)	1414	EN33F	EN33FP	123 x 66	6,5	-	-	-	-

Equipment: 3x 230 V/16 A socket, 3x 230 V/16 A circuit breaker, 1/4" pneumatic quick-connect coupling, 230 V stop button, 1x 400 V/16 A socket, 1x 400 V/16 A circuit breaker, 1x 230 V/6 A circuit breaker, 230 V shunt trip; supplied without power cable (400 V / max 20 A) and pneumatic hose. Supplied **WITHOUT** the bracket for mounting between uprights.



Type E sockets for the Czech Republic and other countries.



Type F sockets for Germany and other countries.



ERGO 240 width 2500 mm				ERGO 400 width 1500 mm				ERGO 400 width 2000 mm				ERGO 400 width 2500 mm			
Order N. without pneum. quick coupling	Order N. with pneum. quick coupling	D x H mm	kg	Order N. without pneum. quick coupling	Order N. with pneum. quick coupling	D x H mm	kg	Order N. without pneum. quick coupling	Order N. with pneum. quick coupling	D x H mm	kg	Order N. without pneum. quick coupling	Order N. with pneum. quick coupling	D x H mm	kg
EN11	EN11P	123 x 66	4,1	-	-	-	-	EN11	EN11P	123 x 66	4,1	EN11	EN11P	123 x 66	4,1
EN13	EN13P	123 x 66	5,6	EN13	EN13P	123 x 66	5,6	-	-	-	-	EN13	EN13P	123 x 66	5,6
EN11F	EN11FP	123 x 66	4,1	-	-	-	-	EN11F	EN11FP	123 x 66	4,1	EN11F	EN11FP	123 x 66	4,1
EN13F	EN13FP	123 x 66	5,6	EN13F	EN13FP	123 x 66	5,6	-	-	-	-	EN13F	EN13FP	123 x 66	5,6

Equipment: 5x 230 V/16 A socket, 3x 230 V/16 A circuit breaker, 1/4" pneumatic quick-connect coupling; supplied without power cable (400 V / max 20 A) and pneumatic hose. Supplied **WITHOUT** the bracket for mounting between uprights.

Order N. without pneum. quick coupling	Order N. with pneum. quick coupling	D x H mm	kg	Order N. without pneum. quick coupling	Order N. with pneum. quick coupling	D x H mm	kg	Order N. without pneum. quick coupling	Order N. with pneum. quick coupling	D x H mm	kg	Order N. without pneum. quick coupling	Order N. with pneum. quick coupling	D x H mm	kg
EN21	EN21P	123 x 66	4,6	-	-	-	-	EN21	EN21P	123 x 66	4,6	EN21	EN21P	123 x 66	4,6
EN23	EN23P	123 x 66	6,2	EN23	EN23P	123 x 66	6,2	-	-	-	-	EN23	EN23P	123 x 66	6,2
EN21F	EN21FP	123 x 66	4,6	-	-	-	-	EN21F	EN21FP	123 x 66	4,6	EN21F	EN21FP	123 x 66	4,6
EN23F	EN23FP	123 x 66	6,2	EN23F	EN23FP	123 x 66	6,2	-	-	-	-	EN23F	EN23FP	123 x 66	6,2

Equipment: 3x 230 V/16 A socket, 1x 230 V/16 A circuit breaker, 1/4" pneumatic quick-connect coupling, 1x 400 V/16 A socket, 1x 400 V/16 A circuit breaker; supplied without power cable (400 V / max 20 A) and pneumatic hose. Supplied **WITHOUT** the bracket for mounting between uprights.

Order N. without pneum. quick coupling	Order N. with pneum. quick coupling	D x H mm	kg	Order N. without pneum. quick coupling	Order N. with pneum. quick coupling	D x H mm	kg	Order N. without pneum. quick coupling	Order N. with pneum. quick coupling	D x H mm	kg	Order N. without pneum. quick coupling	Order N. with pneum. quick coupling	D x H mm	kg
EN31	EN31P	123 x 66	4,9	-	-	-	-	EN31	EN31P	123 x 66	4,9	EN31	EN31P	123 x 66	4,9
EN33	EN33P	123 x 66	6,5	EN33	EN33P	123 x 66	6,5	-	-	-	-	EN33	EN33P	123 x 66	6,5
EN31F	EN31FP	123 x 66	4,9	-	-	-	-	EN31F	EN31FP	123 x 66	4,9	EN31F	EN31FP	123 x 66	4,9
EN33F	EN33FP	123 x 66	6,5	EN33F	EN33FP	123 x 66	6,5	-	-	-	-	EN33F	EN33FP	123 x 66	6,5

Equipment: 3x 230 V/16 A socket, 3x 230 V/16 A circuit breaker, 1/4" pneumatic quick-connect coupling, 230 V stop button, 1x 400 V/16 A socket, 1x 400 V/16 A circuit breaker, 1x 230 V/6 A circuit breaker, 230 V shunt trip; supplied without power cable (400 V / max 20 A) and pneumatic hose. Supplied **WITHOUT** the bracket for mounting between uprights.



**Attachment between uprights**

Order number EKU3ESD  
2 pcs per pack



The electric strip is fixed between the extension uprights using a bracket, **which is NOT** included in the package. We recommend adding a frame around the electric strip to fill the gap between the worktop and the electric strip.



**4 Electrical accessories**

**Lighting**



Color	Width mm	ERGO 240 width 1500 mm			ERGO 240 width 2000 mm		
		Order number	D x H mm	kg	Order number	D x H mm	kg
natural anodized	600	SLIMp30	136 x 26	2,0	SLIMp30	136 x 26	2,0
black anodized	600	SLIMp30B	136 x 26	2,0	SLIMp30B	136 x 26	2,0
natural anodized	1000	SLIMp58	136 x 26	2,4	SLIMp58	136 x 26	2,4
black anodized	1000	SLIMp58B	136 x 26	2,4	SLIMp58B	136 x 26	2,4



Order number	D x H mm	kg	ERGO 400 width 1500 mm			ERGO 400 width 2000 mm			ERGO 400 width 2500 mm		
			Order number	D x H mm	kg	Order number	D x H mm	kg	Order number	D x H mm	kg
SLIMp30	136 x 26	2,0	SLIMp30	136 x 26	2,0	SLIMp30	136 x 26	2,0	SLIMp30	136 x 26	2,0
SLIMp30B	136 x 26	2,0	SLIMp30B	136 x 26	2,0	SLIMp30B	136 x 26	2,0	SLIMp30B	136 x 26	2,0
SLIMp58	136 x 26	2,4	SLIMp58	136 x 26	2,4	SLIMp58	136 x 26	2,4	SLIMp58	136 x 26	2,4
SLIMp58B	136 x 26	2,4	SLIMp58B	136 x 26	2,4	SLIMp58B	136 x 26	2,4	SLIMp58B	136 x 26	2,4

**Mounting for arm extensions**

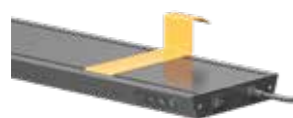

Order number
EKU5ESD

2x cantilever mounted

**Light electronics functions**  
 Plus and Minus Buttons: Adjust the light output between 30% and 80%.  
**Button A:** Activates automatic regulation, which smoothly adjusts the lighting conditions at the workplace based on ambient light.  
**Button B:** Sets the light to maximum (100%) for 5 minutes before returning to the previous setting (80% output).

**Technical description – SLIMp**

An anodized full-aluminum housing with multifunctional longitudinal grooves. Powered at 230 V / 50 Hz with a power consumption of 58 W and 30 W, Mechanical switch, 3 m power cable, LG Innotech LED diodes, Micro-prismatic diffuser – low UGR, Light color – 4000 K color temperature, Capacitive touch control buttons.

**Technical specifications – SLIMp58 luminaire**

Output	Luminous flu	Power Consumption	Light Intensity (1.2 m above work surface)
100%	10 800 lm	58 W	2 750 lx
80%	8 640 lm	46 W	2 200 lx
50%	5 400 lm	29 W	1 380 lx
30%	3 250 lm	17 W	820 lx

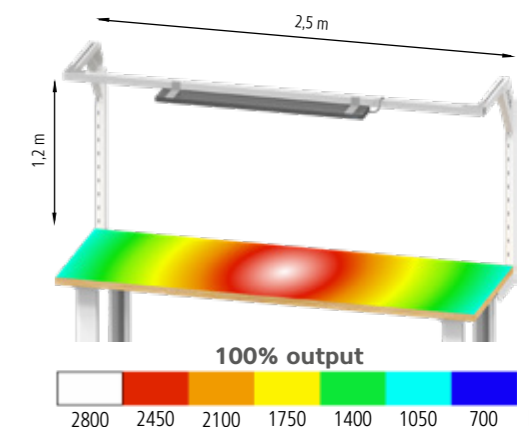

produced in Czechia



configurator | smfu.eu - manual

**ESD ERGO accessories**

**Construction**

The robust and solid construction of the mobile ESD frame allows for the storage and transport of small components and tools for easier handling; finished with ESD paint

**Handle**

For easier handling, finished with ESD paint

**Castors**

in antistatic design  
2x swivel with brake, 2x fixed



**Perforated / solid panels**

Choose from two variants of hanging ESD panels – a perforated panel for attaching the hanging system or a solid panel suitable as a screen

**Hanging system**

Various ESD variants can be found on page 81

**Shelves**

In two depths, finished with ESD paint.

**Fixed shelf**

Part of the mobile frame, finished with ESD paint



**ESD Mobile frame handle**

Order number	20MRERGO1MESD
--------------	---------------

**ESD Solid panel / Perforated panel**

Order number solid panel	Order number perforated panel	H x W mm	kg
8NP10ESD	8NPP10ESD	380 x 1000	3,0
-	8NPP10HESD	190 x 1000	1,7

**ESD Mobile frame ERGO1**

Order number	W x D x H mm	kg	kg
20MRERGO1ESD	1080 x 840 x 1926	280	56

1x bottom shelf, 2x swivel castors KN 100 mm, 2x fixed wheels KNOB 100 m

**ESD Shelves**

Order number	D x W mm	kg
8NPO10-1ESD	206 x 1000	3,2
8NPO10-2ESD	370 x 1000	5,0



**ESD Mobile frame ERGO2**

Order number	W x D x H mm	kg	kg
20MRERGO2ESD	840 x 1080 x 1926	280	57

1x folding shelf, 2x KN 100 mm wheels, 2x KNOB 100 mm wheels. Due to the load capacity of the wheels, we recommend placing a maximum of 3 shelves on the frame. Only ERGO2 shelves can be installed.



**ESD Mobile frame ERGO3**

Order number	W x D x H mm	kg	kg
20MRERGO3ESD	1170 x 1080 x 1926	280	68

1x folding shelf, 2x KN 100 mm wheels, 2x KNOB 100 mm wheels. Due to the load capacity of the wheels, we recommend placing a maximum of 3 shelves on the frame. Only ERGO3 shelves can be installed.



**ESD Folding shelf ERGO2**

Order number	W x D mm	kg	kg
20MRERGO2PESD	706 x 1053	50	15



**ESD Folding shelf ERGO3**

Order number	W x D mm	kg	kg
20MRERGO3PESD	1033 x 1053	50	20,5

**ESD PC Shelf**

Order number	W x D x H mm	kg	kg
20PERGOESD	230 x 530 x 485	10	9,2

For mounting under the tabletop.



**ESD Corner module**

Order number	kg	kg
20RERGOESD	50	20

Ergonomic tables can be connected using a corner module. Tables between which the module is placed must be of the same type and it cannot be used between crank-operated tables.

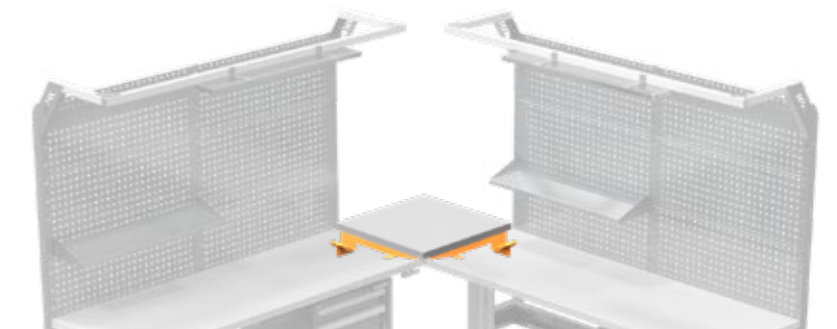

# Electrical accessories



## Electric strips

Fully aluminium-certified electric strips, the core component of POLAK workshop furniture electrical accessories. **Durable construction, flip-down front cover for easy maintenance, and elegant design.** Protective components ensure the safety of the user and their electrical equipment.

For greater usability, we have integrated a pneumatic quick coupling into the electric strips. This makes them applicable in many situations and compatible with other workshop furniture products. **They are supplied with type F electrical sockets, used for example in Germany, and type E sockets for the Czech Republic.**



### Electric strip mounting

Thanks to several mounting options of POLAK electric strips and extension cords, their use in combination with other components of workshop furniture is truly versatile. Magnetic mounting in particular provides real freedom – all you need is a metal counterpart – for each individual POLAK furniture piece.

Electric strips designed for integration into drawer cabinets can be found in the Drawer Cabinet chapter.



### Frame for electric strip

Covers the gap around the electric strip in the workbench superstructure. More information **on page 67** in the Workbench Accessories chapter or at [www.smfu.eu](http://www.smfu.eu).



Type E socket

Catalog marking E (CZ)

so-called French type, used in the Czech Republic and other countries

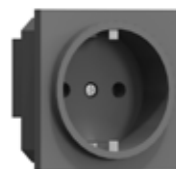

Type F socket

Catalog marking F (DE)

so-called German type, used in Germany and other countries



Electric stripe EN V1

Socket type	Order N. without pneum. quick coupling	Order N. with pneum. quick coupling	W x D x H mm	kg
E (CZ)	EN11	EN11P	934 x 123 x 66	4,1
E (CZ)	EN12	EN12P	1114 x 123 x 66	4,7
E (CZ)	EN13	EN13P	1414 x 123 x 66	5,6
F (DE)	EN11F	EN11FP	934 x 123 x 66	4,1
F (DE)	EN12F	EN12FP	1114 x 123 x 66	4,7
F (DE)	EN13F	EN13FP	1414 x 123 x 66	5,6

5x 230 V / 16 A socket, 3x 230 V / 16 A circuit breaker, 1/4" pneumatic quick-connect coupling, supplied without power cable (400 V / max 20 A) and pneumatic hose.



Electric stripe EN V3

Socket type	Order N. without pneum. quick coupling	Order N. with pneum. quick coupling	W x D x H mm	kg
E (CZ)	EN31	EN31P	934 x 123 x 66	4,9
E (CZ)	EN32	EN32P	1114 x 123 x 66	5,5
E (CZ)	EN33	EN33P	1414 x 123 x 66	6,5
F (DE)	EN31F	EN31FP	934 x 123 x 66	4,9
F (DE)	EN32F	EN32FP	1114 x 123 x 66	5,5
F (DE)	EN33F	EN33FP	1414 x 123 x 66	6,5

3x 230 V / 16 A socket, 3x 230 V / 16 A circuit breaker, 1/4" pneumatic quick-connect coupling, 230 V stop button, 1x 400 V / 16 A socket, 1x 400 V / 16 A circuit breaker, 1x 230 V / 6 A circuit breaker, 230 V shunt trip, supplied without power cable (400 V / max 20 A) and pneumatic hose.



Electric stripe K1 36D

Socket type	Order number	W x D x H mm	kg
E (CZ)	EK136	657 x 123 x 66	3,0
F (DE)	EK136F	657 x 123 x 66	3,0

3x 230 V / 10 A socket, 1x 230 V / 10 A switch, 230 V / 10 A residual current circuit breaker with overcurrent protection (RCBO), 1/4" pneumatic quick-connect coupling, supplied without power cable (230 V / max 16 A) and pneumatic hose.



Electric stripe EN V2

Socket type	Order N. without pneum. quick coupling	Order N. with pneum. quick coupling	W x D x H mm	kg
E (CZ)	EN21	EN21P	934 x 123 x 66	4,6
E (CZ)	EN22	EN22P	1114 x 123 x 66	5,2
E (CZ)	EN23	EN23P	1414 x 123 x 66	6,2
F (DE)	EN21F	EN21FP	934 x 123 x 66	4,6
F (DE)	EN22F	EN22FP	1114 x 123 x 66	5,2
F (DE)	EN23F	EN23FP	1414 x 123 x 66	6,2

3x 230 V / 16 A socket, 1x 230 V / 16 A circuit breaker, 1/4" pneumatic quick-connect coupling, 1x 400 V / 16 A socket, 1x 400 V / 16 A circuit breaker, supplied without power cable (400 V / max 20 A) and pneumatic hose.

### Electric strip mounting components



#### Mounting to table top and table leg

Order number: EKU1ESD  
2 pcs per pack



#### Magnetic mounting

Order number: EKU2  
4 pcs per pack



#### Attachment between uprights

Order number: EKU3ESD  
2 pcs per pack



Electric stripe K2 36D

Socket type	Order number	W x D x H mm	kg
E (CZ)	EK236	657 x 123 x 66	3,1
F (DE)	EK236F	657 x 123 x 66	3,1

3x 230 V / 10 A socket, 1x 230 V / 10 A switch, RJ45 data socket, 230 V / 10 A residual current circuit breaker with overcurrent protection (RCBO), 1/4" pneumatic quick-connect coupling, supplied without power cable (230 V / max 16 A), data cable, and pneumatic hose.

### Extension cords

Certified extension cords designed for craft and industrial use. **The slim all-aluminium body stands out with its simple yet durable construction.** The rear panel includes grooves for various mounting methods.

It is a small yet important component in the electrification of your workshop. **Supplied with type F sockets used, for example, in Germany, and type E sockets for the Czech Republic.**



#### Mounting of extension cords

Thanks to several mounting methods of POLAK electric strips and extension cords, they can be widely used in combination with other workshop furniture components. Magnetic mounting provides real flexibility – you only need a metal counterpart – for every single piece of POLAK furniture.

Electric strips intended for installation into drawer cabinets can be found in the Drawer Cabinet chapter.



#### Components for extension cord mounting



Type E socket

Catalog marking E (CZ)

so-called French type, used in the Czech Republic and other countries



Type F socket

Catalog marking F (DE)

so-called German type, used in Germany and other countries



#### Mounting to table top and table leg

Order number EKU4ESD  
2 pcs per pack



#### Magnetic mounting

Order number EKU2  
4 pcs per pack



Extension cord 250 mm

Socket type	Order number	W x D x H mm	kg
E (CZ)	PP250	250 x 73 x 34	0,8
F (DE)	PP250F	250 x 73 x 34	0,8

3x socket 230 V / 16 A, 1x switch 230 V / 16 A, 3 m power cable exiting from the side of the profile



Extension cord 400 mm

Socket type	Order number	W x D x H mm	kg
E (CZ)	PP400	400 x 73 x 34	1,1
F (DE)	PP400F	400 x 73 x 34	1,1

5x socket 230 V / 16 A, 1x switch 230 V / 16 A, 3 m power cable exiting from the side of the profile



Extension cord 700 mm

Socket type	Order number	W x D x H mm	kg
E (CZ)	PP700	700 x 73 x 34	1,7
F (DE)	PP700F	700 x 73 x 34	1,7

9x socket 230 V / 16 A, 1x switch 230 V / 16 A, 3 m power cable exiting from the side of the profil



Extension cord 400 mm s USB

Socket type	Order number	W x D x H mm	kg
E (CZ)	PP400USB	405 x 73 x 34	1,1
F (DE)	PP400FUSB	405 x 73 x 34	1,1

4x socket 230 V / 16 A, 2x USB, 1x switch 230 V / 16 A, 3 m power cable exiting from the side of the profil

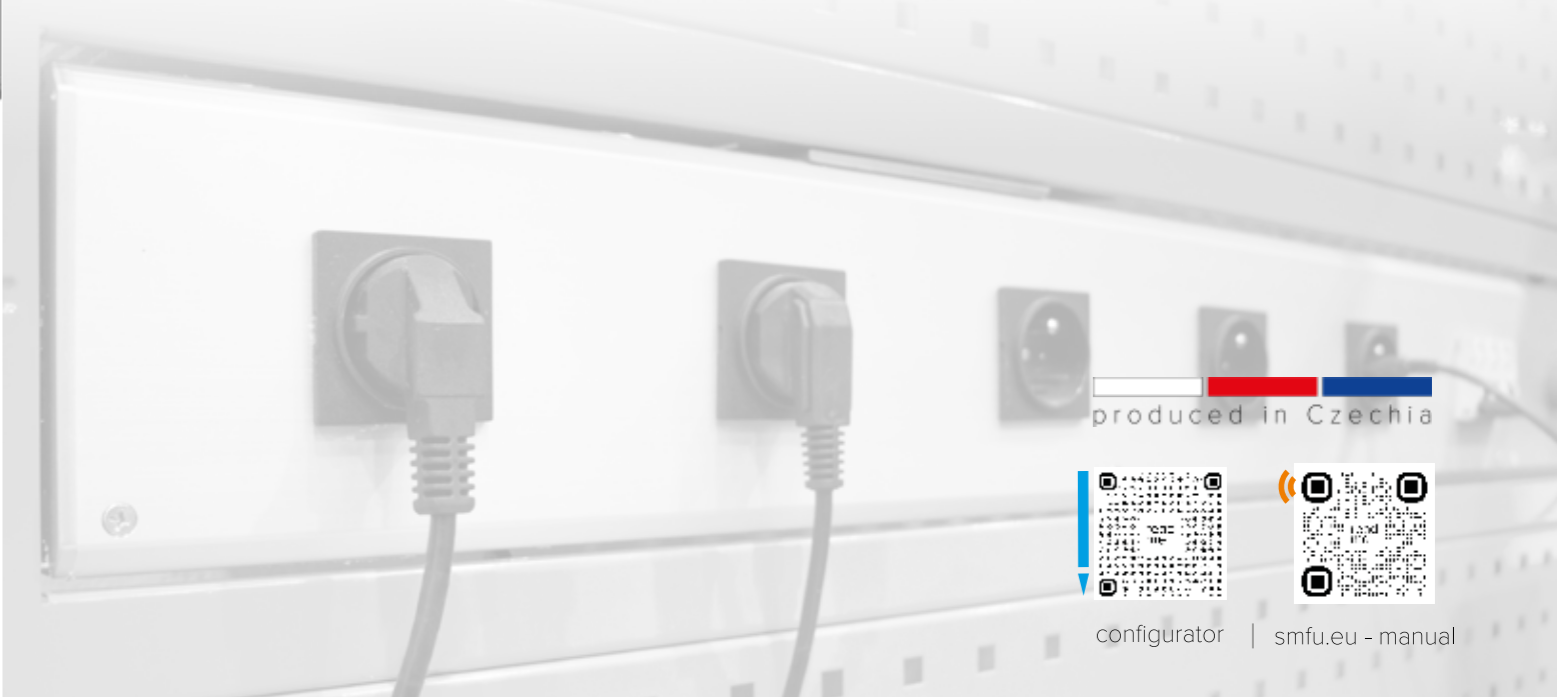

produced in Czechia



configurator

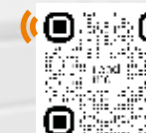

smfu.eu - manual

## Lighting

In lighting, **POLAK** has opted for in-house development and the modern trend – maximum energy savings with maximum performance. Original aluminium light housing, original electronics, LED technology, high-quality workmanship – these are the SLIMp light fittings manufactured by POLAK. **They combine elegant, slim design with excellent performance parameters.**

### Technical description – SLIMp

An anodized full-aluminum housing with multifunctional longitudinal grooves. **Powered at 230 V / 50 Hz with a power consumption of 58 W and 30 W**, Mechanical switch, 3 m power cable, LG Innotek LED diodes, Micro-prismatic diffuser – low UGR, Light color – **4000 K color temperature**, Capacitive touch control buttons.



configurator



3+ RAL colors



smfu.eu - manual

### Light electronics functions

Plus and Minus Buttons: Adjust the light output between 30% and 80%.

**Button A:** Activates automatic regulation, which smoothly adjusts the lighting conditions at the workstation based on ambient light.

**Button B:** Sets the light to maximum (100%) for 5 minutes before returning to the previous setting (80% output).



### SLIMp Lighting

Order number natural anodized	Order number black anodized	W x D x H mm	kg
SLIMp58	SLIMp58B	1000 x 136 x 26	2,4
SLIMp30	SLIMp30B	600 x 136 x 26	2,0

### LED Light mounting



Magnetic mounting is especially suitable for POLAK inspection workstations – fastening to the metal ceiling of the workstation.

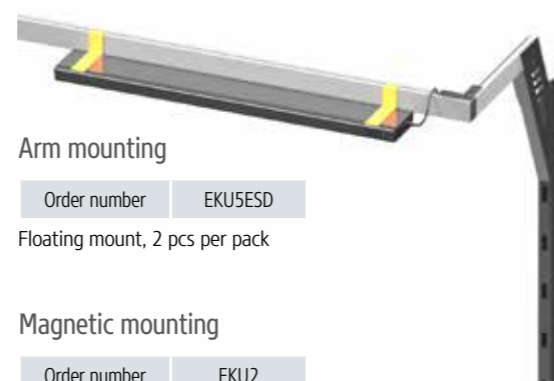

### Arm mounting

Order number EKU5ESD  
Floating mount, 2 pcs per pack

### Magnetic mounting

Order number EKU2

### SLIMp lamp

Order number natural anodized	Order number black anodized	W x D x H mm	kg
SLIMp17	SLIMp17B	200 x 136 x 26	1,3

Flexible tube length 600 mm.  
The lamp is supplied without mounting components.



Thanks to the flexible, shapeable tube, you can illuminate your work surface exactly as needed.

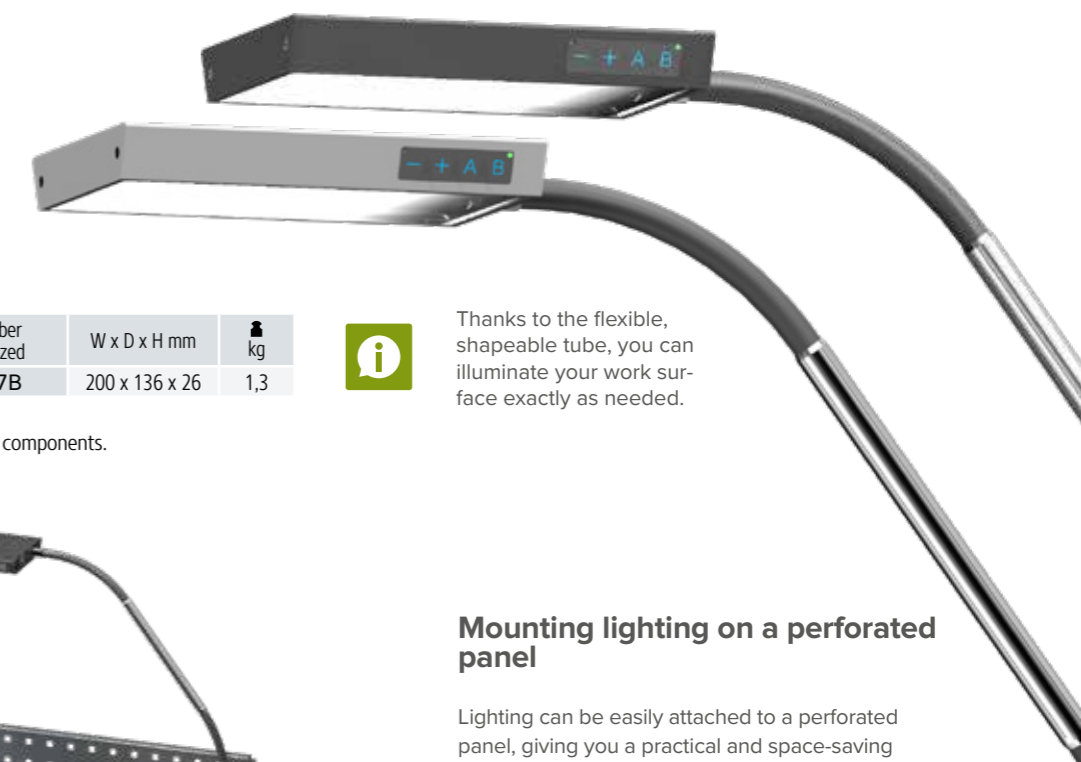

### Mounting lighting on a perforated panel

Lighting can be easily attached to a perforated panel, giving you a practical and space-saving workplace solution. SLIMp luminaires can thus be placed exactly where needed, ensuring optimal illumination of the work surface without limiting its usability.

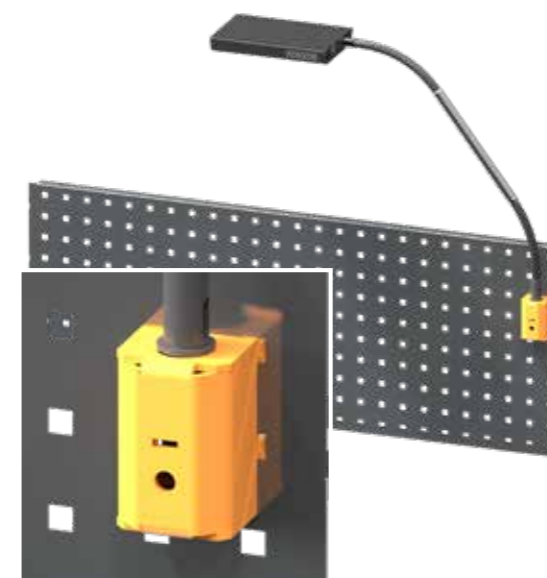

### Mounting on a perforated panel

Order number EKU7ESD  
Swivel design.

### Technical specifications – SLIMp58 luminaire

Output	Luminous flu	Power consumption	Light intensity (1.2 m above work surface)
100%	10 800 lm	58 W	2 750 lx
80%	8 640 lm	46 W	2 200 lx
50%	5 400 lm	29 W	1 380 lx
30%	3 250 lm	17 W	820 lx

### Technical specifications – SLIMp17 luminaire

Output	Luminous flu	Power consumption	Light intensity (0.6 m above work surface)
100%	2 350 lm	17 W	1 880 lx
80%	1 872 lm	14 W	1 500 lx
50%	1 170 lm	9 W	940 lx
30%	700 lm	6 W	560 lx

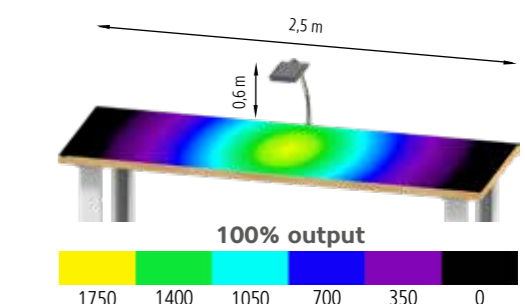
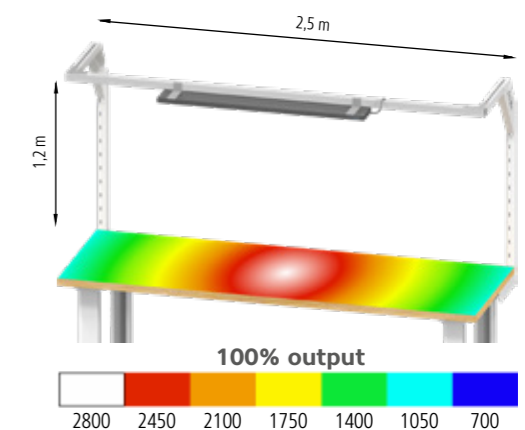

## Workshop cabinets



Workshop cabinets are designed for demanding conditions, not only in engineering operations. **SK series cabinets with wing doors with a 180° opening angle are optimized for the use of a hanging system and drawers of sizes 54 x 27D, offering a complete configuration of individual components.** The cabinets are lockable with the original POLAK Design system and meet safety glass requirements for variants with glass doors.

By using an antistatic design, protection of materials and tools against electrostatic discharge is achieved. **Metal parts of the cabinet are finished with ESD paint and grounding points**, while small plastic parts such as lock bodies, handles, and labels are not ESD conductive. The cabinets meet the requirements of the **ČSN EN 61340-5-1** standard.



- 1** Cabinet body available in two depths (SK1 – 635 mm and SK2 – 435 mm), two heights (1030 and 1930 mm), with solid or glass doors, in ESD design
- 2** Drawers full extension, the drawer is equipped with a description label and smooth full extension, finished with ESD paint
- 3** Rear wall panels perforated ESD panel for mounting on the rear wall of the cabinet, width 1012 mm, suitable for the hanging system
- 4** Side wall panels perforated ESD panel in two widths for mounting to the side of the cabinet, suitable for the hanging system
- 5** Door panel perforated ESD panel for mounting on the cabinet door, width 350 mm, suitable for the hanging system
- 6** Accessories the cabinet can be further equipped with a plinth, shelves, document pockets, hanging system, or boxes, in ESD design

## SK cabinet variants

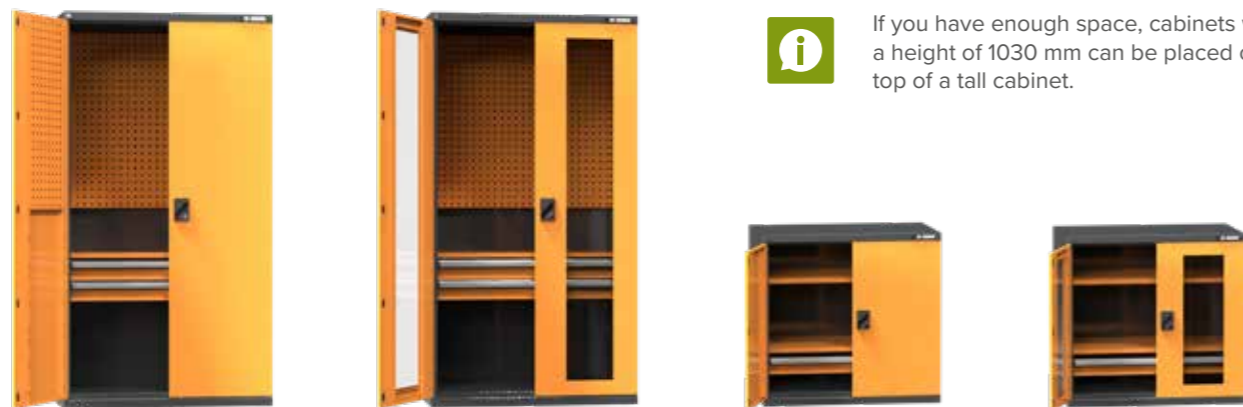

**i** If you have enough space, cabinets with a height of 1030 mm can be placed on top of a tall cabinet.



**i** **Information label and protective drawer corners**  
Elegant plastic termination of the drawer handle with space for a description label. The label is protected by a transparent cover and plastic plugs on the sides.



**Full extension**  
The slide construction ensures 100% drawer extension and allows access to its entire surface. The guide rails of the extension mechanism are in the side walls of the cabinet bodies, adjustable in 25 mm increments. Smooth, quiet operation, maximum load 80 kg.

## SK Cabinet Doors

We offer workshop cabinets in two door design variants – with solid doors and with glass doors. Glass doors use toughened safety glass.

Both variants are equipped with the original POLAK design two-point locking lock with quiet operation.



## Perforated panels

It is suitable to equip the SK workshop cabinet with perforated panels, which can be placed on the cabinet doors (solid only), on the side walls, or on the rear wall. You can easily attach a hanging system to the perforated panels and thus utilize the space inside the cabinet to the maximum. The hanging system range can be found on page 81.

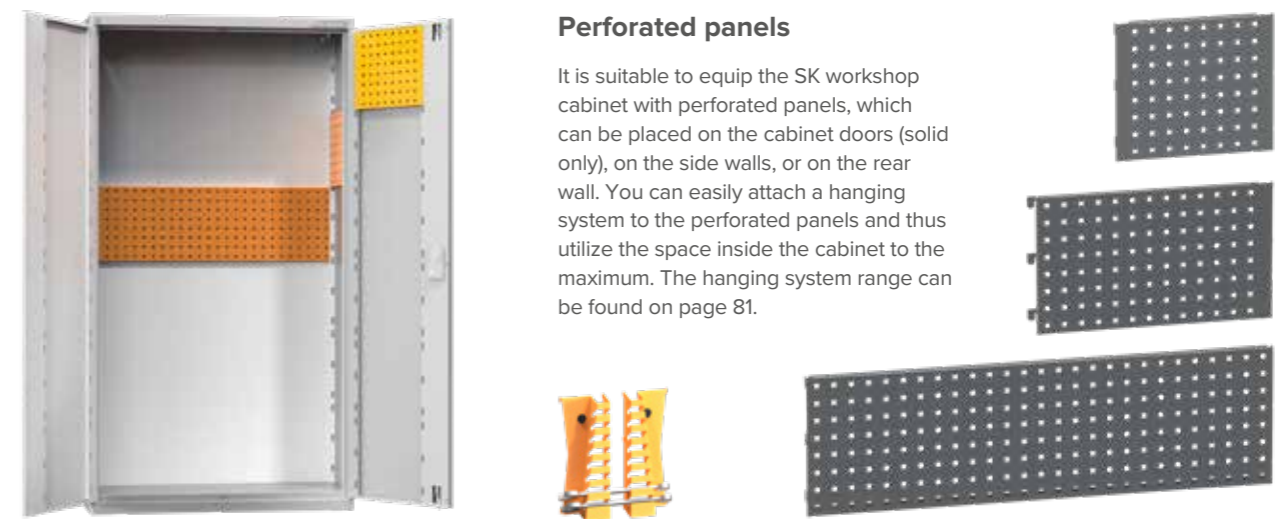

Standard configuration SK1

Height 1000 mm



Width 1044 mm, Depth 655 mm

Doors	Order number	kg	kg
Solid	SK1-004ESD	500	54
Glass	SK1-004SESD	500	57

2 shelves, tempered safety glass.



Width 1044 mm, Depth 655 mm

Doors	Order number	kg	kg
Solid	SK1-006ESD	500	75
Glass	SK1-006SESD	500	81

1 shelf, drawer 100E, perforated doors, perforated side walls, perforated rear wall, tempered safety glass.

Height 1950 mm



Width 1044 mm, Depth 655 mm

Doors	Order number	kg	kg
Solid	SK1-001ESD	500	96
Glass	SK1-001SESD	500	98

4 shelves, tempered safety glass.



Width 1044 mm, Depth 655 mm

Doors	Order number	kg	kg
Solid	SK1-003ESD	500	137
Glass	SK1-003SESD	500	139

1 shelf, 2 drawers 100E, perforated doors, perforated side walls, perforated rear wall, tempered safety glass.

Standard configuration SK2

Height 1000 mm



Width 1044 mm, Depth 405 mm

Doors	Order number	kg	kg
Solid	SK2-002ESD	500	44
Glass	SK2-002SESD	500	45

2 shelves, tempered safety glass.



Width 1044 mm, Depth 405 mm

Doors	Order number	kg	kg
Solid	SK2-004ESD	500	52
Glass	SK2-004SESD	500	53

1 shelf, perforated doors, perforated side walls, perforated rear wall, tempered safety glass.

Height 1950 mm



Width 1044 mm, Depth 405 mm

Doors	Order number	kg	kg
Solid	SK2-001ESD	500	83
Glass	SK2-001SESD	500	84

3 shelves, tempered safety glass.



Width 1044 mm, Depth 405 mm

Doors	Order number	kg	kg
Solid	SK2-003ESD	500	93
Glass	SK2-003SESD	500	94

2 shelves, perforated doors, perforated side walls, perforated rear wall, toughened safety glass.



**Workshop cabinets UK**

UK series cabinets with wing doors with an opening angle of more than 90 are a lighter form of workshop cabinets. They are primarily used for storing smaller and lighter materials, or as storage for plastic boxes for smaller items. Metal parts of the cabinets **are finished with ESD paint and grounding points**, while small plastic parts **such as lock bodies, handles, and labels**

**are not ESD conductive.** The cabinets meet the requirements of the **ČSN EN 61340-5-1** standard. Variants with glass doors use toughened safety glass. The cabinets are lockable with the original **POLAK** design lock of a **two-point locking system** with quiet operation. Shelves are height-adjustable.

- 1** Cabinet body  
available in two widths (700 and 950 mm), height 1930 mm, and depth 400 mm
- 2** Doors  
with a 90 opening angle; we offer doors in solid or glass variants; UK cabinets are also supplied without doors
- 3** Plastic boxes  
suitable for this type of cabinet; available in 6 sizes and 5 color variants
- 4** Accessories  
the cabinet can be equipped with a plinth and shelves

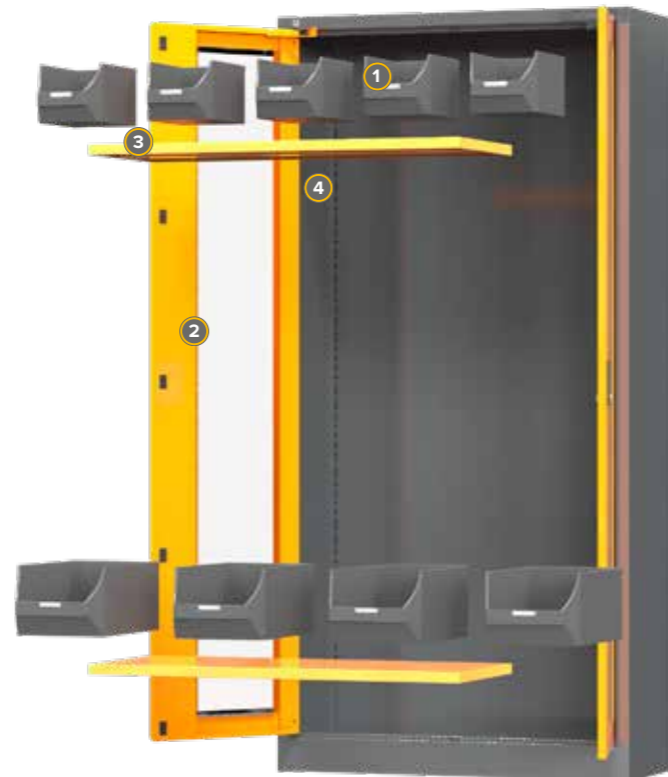

**i** We offer UK cabinets in a variant without doors. To fill the cabinet with plastic boxes, we recommend using the POLAK workshop furniture configurator.



**UK cabinet variants**



**ESD plastic boxes**



Order number	W x D x H
456142	300 x 500 x 200



Order number	W x D x H
456132	200 x 350 x 150



Order number	W x D x H
456122	145 x 235 x 125



Order number	W x D x H
456107	100 x 175 x 75



Order number	W x D x H
456102	100 x 100 x 60

Plastic boxes are **manufactured from antistatic plastic**. They are designed with semiconductive PP (dissipative) properties, meeting the requirements of **antistatic workplaces**. The bottom of the box is designed for easier gripping of small items. **The boxes are equipped with a peripheral reinforcing rim for greater strength**, a large recessed handle with space for a description label, and a rear hanging rail.



produced in **Czechia**



configurator | smfu.eu - manual

### Standard configuration UK1

Width 950 mm



Depth 400 mm, Height 1950 mm

Doors	Order number	kg	kg
Solid	UK1-001ESD	400	71
Glass	UK1-001SESD	400	75

4x shelf, toughened safety glass



Depth 400 mm, Height 1950 mm

Doors	Order number	kg	kg
Solid	UK1-B11ESD	400	110
Glass	UK1-B11SESD	400	114

9x shelf, toughened safety glass, box size 4 – 40 pcs



Depth 400 mm, Height 1950 mm

Doors	Order number	kg	kg
Solid	UK1-B21ESD	400	107
Glass	UK1-B21SESD	400	111

9x shelf, toughened safety glass, box size 4 – 24 pcs, box size 3 – 20 pcs

### Standard configuration UK2

Width 700 mm



Depth 400 mm, Height 1950 mm

Order number	kg	kg
UK2-001ESD	400	59

4x shelf



Depth 400 mm, Height 1950 mm

Order number	kg	kg
UK2-B11ESD	400	84

10x shelf, box size 3 – 44 pcs



Depth 400 mm, Height 1950 mm

Order number	kg	kg
UK2-B21ESD	400	89

12x shelf, box size 3 – 32 pcs, box size 2 – 30 pcs

### Standard configuration UK without doors

Width 950 mm



Depth 400 mm, Height 1950 mm

Order number	kg	kg
UK1-B1ESD	400	95

9x shelf, box size 4 – 40 pcs



Depth 400 mm, Height 1950 mm

Order number	kg	kg
UK1-B2ESD	400	85

9x shelf, box size 4 – 24 pcs, box size 3 – 20 pcs

Šířka 700 mm



Depth 400 mm, Height 1950 mm

Order number	kg	kg
UK2-B1ESD	400	69

10x shelf, box size 3 – 44 pcs

Custom configuration of SK and UK cabinets



1044 x 655 mm

1 Cabinet body

Workshop cabinet	Height mm	Doors	Cabinet SK1 depth 655 mm		
			Order number	kg	kg
	1950	Solid	SK1-100ESD	500	72
		Glass	SK1-100SESD	500	75
	1000	Solid	SK1-200ESD	500	43
		Glass	SK1-200SESD	500	46

2 Cabinet equipment

Drawer	Front height A mm	Front height C mm	Cabinet SK1 depth 655 mm		
			Order number full extension	kg	kg
	75	50	ZCE75RES	80	10,3
	100	75	ZCE100RES	80	11,0
	125	75	ZCE125RES	80	11,4
	150	125	ZCE150RES	80	12,4
	200	175	ZCE200RES	80	13,9
	250	175	ZCE250RES	80	14,6
	300	275	ZCE300RES	80	16,7

Full extension  
80 kg

For the 1950 mm cabinet, we recommend equipping it with drawers up to a maximum height of 1000 mm.

Perforated panels	Purpose	Order number	Width mm	kg
	For the side wall	SK1-P2ESD	528	1,1 / ks
	For the rear wall	SK1-P3ESD	1032	2,3 / ks
	Document pocket	SK1-P4ESD	350	1,2 / ks

The document pocket is designed to be attached to the cabinet doors (solid only)

Shelf / Plinth	Type	Sheet metal thickness	Order number	kg	kg
	Plinth	SK1-SOESD	-	19,1	

The shelf is height-adjustable in 25 mm increments; plinth height is 100 mm



1044 x 405 mm



950 x 400 mm



700 x 400 mm

Cabinet SK2 depth 405 mm			Cabinet UK1 width 950 mm			Cabinet UK2 width 700 mm		
Order number	kg	kg	Order number	kg	kg	Order number	kg	kg
SK2-100ESD	500	63	UK1-100ESD	400	57	UK2-100ESD	400	49
SK2-100SESD	500	66	UK1-100SESD	400	61	-	-	-
SK2-200ESD	500	43	-	-	-	-	-	-
SK2-200SESD	500	46	-	-	-	-	-	-

Cabinet SK2 depth 405 mm			Cabinet UK1 width 950 mm			Cabinet UK2 width 700 mm		
Order number full extension	kg	kg	Order number full extension	kg	kg	Order number full extension	kg	kg
-	-	-	-	-	-	-	-	-
-	-	-	-	-	-	-	-	-
-	-	-	-	-	-	-	-	-
-	-	-	-	-	-	-	-	-
-	-	-	-	-	-	-	-	-
-	-	-	-	-	-	-	-	-

For the 1950 mm cabinet, we recommend equipping it with drawers up to a maximum height of 1000 mm.

Order number	Width mm	kg	Order number	Width mm	kg	Order number	Width mm	kg
SK2-P2ESD	308	1,0 / ks	-	-	-	-	-	
SK1-P3ESD	1032	2,3 / ks	-	-	-	-	-	
SK1-P4ESD	350	1,2 / ks	-	-	-	-	-	

The document pocket is designed to be attached to the cabinet doors (solid only)

Order number	kg	kg	Order number	kg	kg	Order number	kg	kg
SK2-SOESD	-	19,1	UK1-SOESD	-	13,5	UK2-SOESD	-	9,2

The shelf is height-adjustable in 25 mm increments; plinth height is 100 mm



**POLAK CZ s.r.o.**  
569 12 Opatov 348  
Czech Republic  
info@polakcz.cz  
www.polakcz.cz

© copyright POLAK CZ 2026

 electronic catalog on [www.polakcz.cz](http://www.polakcz.cz)

creation, design	_____	polak cz
design, corrections	_____	ameo svitavy
print	_____	h.r.g. litomyšl

This catalogue contains technical data valid as of the date of its publication; these can change during its validity owing to continuous development. For current information, see [www.polakcz.cz](http://www.polakcz.cz) and [www.smfu.eu](http://www.smfu.eu). Terms of trade at [www.polakcz.cz](http://www.polakcz.cz).

The publisher bears no responsibility for deviations of printed colours from reality; these minor deviations are caused by the printing process. The colour scheme of the illustrative pictures and photos constitutes no responsibility of the manufacturer to supply them in this design.

This catalog is part of the POLAK CZ catalog family.



workshop furniture



overview



SySEL



ESD program



Clothes lockers for IRS



lukáš



pepa



martin



miloš



zuzka



adam



pavlína